

THE INFORMATION CONTAINED IN THIS DRAWING IS THE SOLE PROPERTY OF ANDERSON POWER PRODUCTS. ANY REPRODUCTION IN PART OR WHOLE WITHOUT THE WRITTEN PERMISSION OF ANDERSON POWER PRODUCTS IS PROHIBITED.

DATE	9/19/08
BY:	CMS
DESCRIPTION OF CHANGES	ECRN 14323: 1.95 WAS 1.86, .41 WAS .40, 1.60 WAS 1.56, .26 WAS .31, TOLERANCES
REV.	1

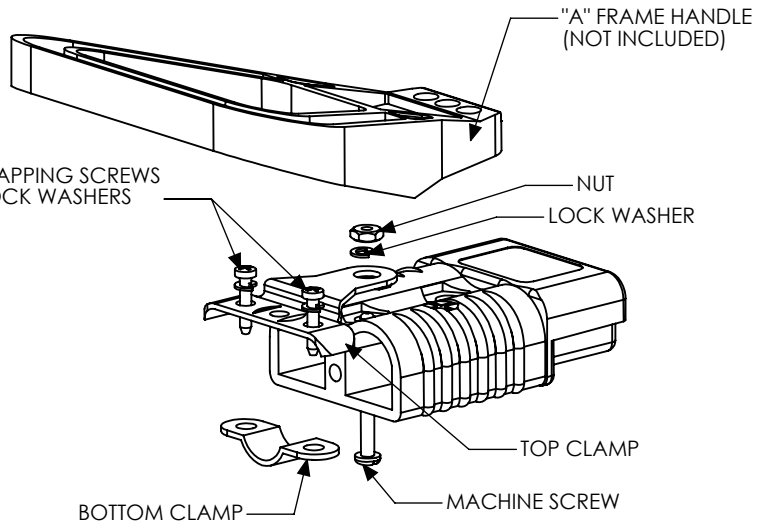
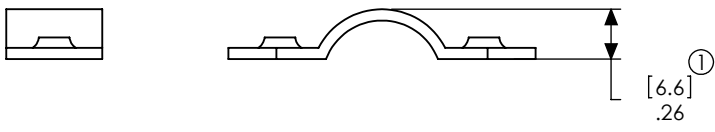
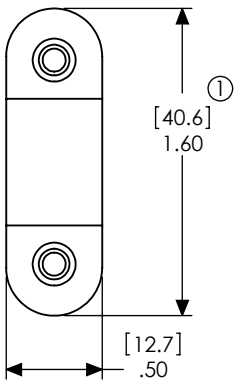
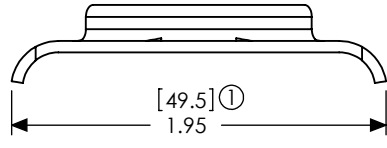
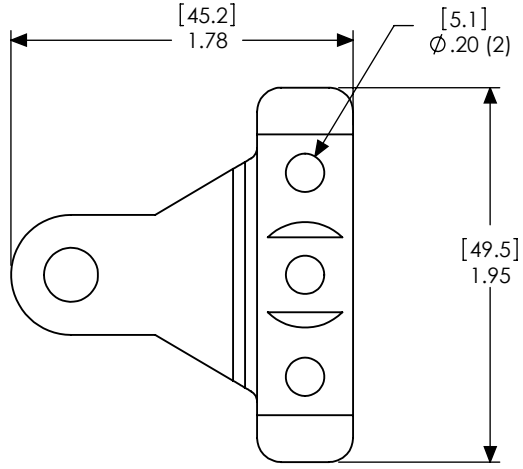

NOTES:

1. MATERIAL- COLD ROLLED STEEL; ZINC PLATE- YELLOW
2. HARDWARE KIT INCLUDES-TWO SELF TAPPING SCREWS ONE MACHINE SCREW, ONE NUT, AND THREE LOCK WASHERS
3. CONNECTOR AND "A" FRAME HANDLE SOLD SEPARATELY

ITEM NO.	PART OR IDENTIFYING NO.	NOMENCLATURE OR DESCRIPTION	MATERIAL SPECIFICATION	QTY REQD
COPYRIGHT 2000 ANDERSON POWER PRODUCTS. ALL RIGHTS RESERVED. UNAUTHORIZED REPRODUCTION HEREBY PROHIBITED.				
DIMENSIONS ARE IN INCHES DIMENSIONS IN PARENTHESES [] ARE IN MILLIMETERS		CAD GENERATED DRAWING, DO NOT MANUALLY UPDATE		
TOLERANCES ARE: 2PL- ±.05 [±1.3]		APPROVALS DATE		
MATERIALS: SEE NOTES		DRAWN CMS 2/8/00		
FINISH SEE NOTES		CHECKED DJD 2/9/00		
DO NOT SCALE DRAWING		RESP ENG UFN 2/9/00		
		MFG ENG CHB 2/9/00		
		QUAL ENG RPO 2/10/00		
		SCALE NONE		REV. 1
		CADFILES/01188		SHEET 1 OF 1

ANDERSON POWER PRODUCTS

CATALOG NUMBER 946G1
SB175 CABLE CLAMP FOR
TWIN CONDUCTOR CABLE
FOR USE WITH "A" FRAME HANDLE

SIZE A SPECIFICATION: 114230S1