

THE INFORMATION CONTAINED IN THIS DRAWING IS THE SOLE PROPERTY OF ANDERSON POWER PRODUCTS. ANY REPRODUCTION IN PART OR WHOLE WITHOUT THE WRITTEN PERMISSION OF ANDERSON POWER PRODUCTS IS PROHIBITED.

ANDERSON POWER PRODUCTS RESERVES THE RIGHT TO ALTER PRODUCT TYPES, THEIR TECHNICAL DATA, DIMENSION, STYLE AND ACCESSORIES WITHOUT PRIOR NOTIFICATION.

REV.	DESCRIPTION OF CHANGES	BY:	DATE
2	ECRN: 13212- REDRAWN	CMS	6/15/99
3	ECRN 14110 - REDRAWN	AMS	3/1/07
4	ECRN-14970 INCLUDING 200G3L	TWE	9/1/11

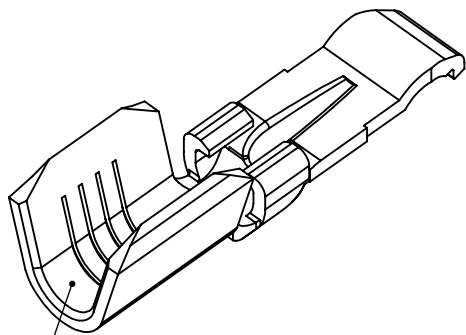

BARREL SIZED FOR #10-14 AWG WIRE

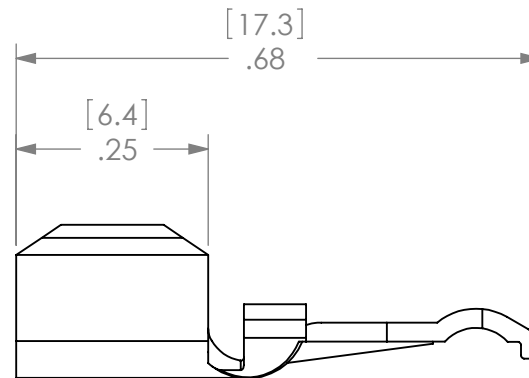
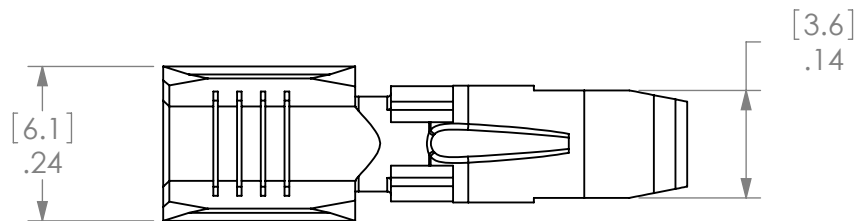
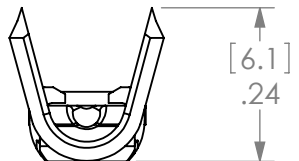

CATALOG #	PLATING
200G1L	HOT TIN DIP
200G3L	SILVER

NEXT ASSY	USED ON	APPLICATION
		DO NOT SCALE DRAWING

ITEM NO.	PART OR IDENTIFYING NO.	NOMENCLATURE OR DESCRIPTION	MATERIAL SPECIFICATION	QTY REQD
COPYRIGHT 2002 ANDERSON POWER PRODUCTS. ALL RIGHTS RESERVED. UNAUTHORIZED REPRODUCTION HEREBY PROHIBITED.				
DIMENSIONS ARE IN INCHES DIMENSIONS IN PARENTHESES [] ARE IN MILLIMETERS		CAD GENERATED DRAWING, DO NOT MANUALLY UPDATE		<b>ANDERSON POWER PRODUCTS</b>  200G SERIES LOW DETENT REELED CONTACT FOR #10-#14 AWG WIRE
TOLERANCES ARE: 2PL- ±.02 [±.5]		APPROVALS	DATE	
MATERIALS: <i>COPPER</i>		DRAWN	GN 6/30/99	
FINISH <i>SEE TABLE</i>		CHECKED	DJD 9/19/00	
NEXT ASSY		RESP ENG	UFN 9/20/00	
USED ON		MFG ENG	CHB 9/19/00	SIZE A
APPLICATION		QUAL ENG	RPO 9/19/00	SPECIFICATION: 114116S1
		SCALE NONE		REV. 4
		FILE: CADFILES/00981		SHEET 1 OF 1