

THE INFORMATION CONTAINED IN THIS DRAWING IS THE SOLE PROPERTY OF ANDERSON POWER PRODUCTS. ANY REPRODUCTION IN PART OR WHOLE WITHOUT THE WRITTEN PERMISSION OF ANDERSON POWER PRODUCTS IS PROHIBITED.

DATE	**
BY:	**
DESCRIPTION OF CHANGES	**
REV.	**

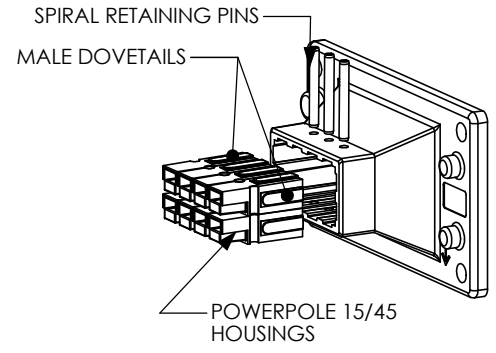
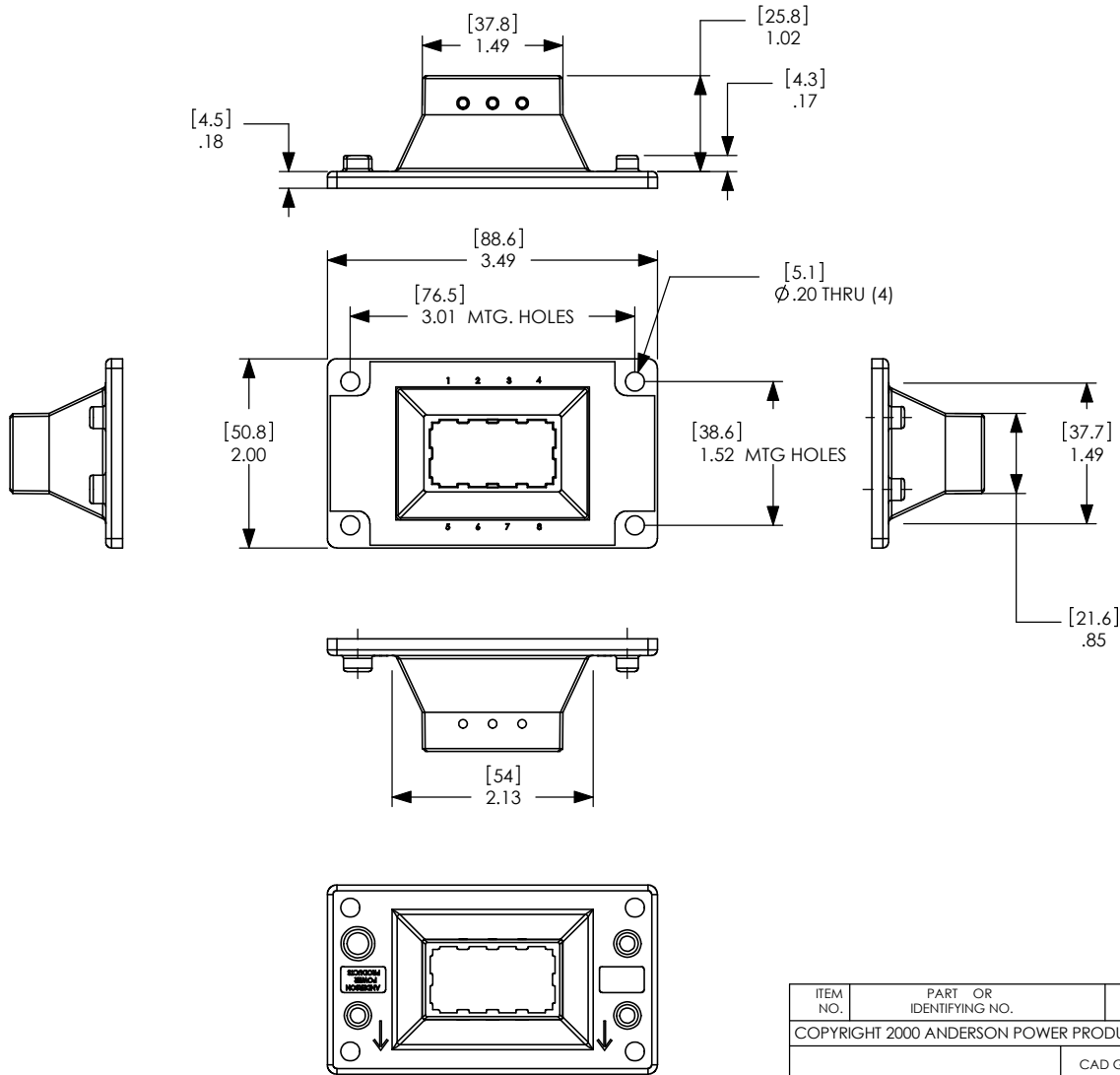

TYPICAL ASSEMBLY

NEXT ASSY	USED ON
APPLICATION	DO NOT SCALE DRAWING

ITEM NO.	PART OR IDENTIFYING NO.	NOMENCLATURE OR DESCRIPTION	MATERIAL SPECIFICATION	QTY REQD
COPYRIGHT 2000 ANDERSON POWER PRODUCTS. ALL RIGHTS RESERVED. UNAUTHORIZED REPRODUCTION HEREBY PROHIBITED.				
DIMENSIONS ARE IN INCHES DIMENSIONS IN PARENTHESES [] ARE IN MILLIMETERS		CAD GENERATED DRAWING. DO NOT MANUALLY UPDATE		ANDERSON POWER PRODUCTS
TOLERANCES ARE: 2PL- ±.02 [±.5]		APPROVALS	DATE	
MATERIALS: PC- UL94-V0		DRAWN	CMS 3/2/01	BLINDMATE POWERPOLE PAK FLOATING PLUG
FINISH AS MOLDED		CHECKED	DJD 3/2/01	
		RESP ENG	UFN 3/18/01	SIZE c
		MFG ENG	CHB 4/2/01	SPECIFICATION: 2-8348S1
		QUAL ENG	RPO 3/19/01	REV. 0
		SCALE	NONE	CADFILES/01388
		SHEET 1 OF 1		