

THE INFORMATION CONTAINED IN THIS DRAWING IS THE SOLE PROPERTY OF ANDERSON POWER PRODUCTS. ANY REPRODUCTION IN PART OR WHOLE WITHOUT THE WRITTEN PERMISSION OF ANDERSON POWER PRODUCTS IS PROHIBITED.

Copyright 2006

ANDERSON POWER PRODUCTS RESERVES THE RIGHT TO ALTER PRODUCT TYPES, THEIR TECHNICAL DATA, DIMENSION, STYLE AND ACCESSORIES WITHOUT PRIOR NOTIFICATION.

THESE DIMENSIONS SHOWN WITH THE HANDLE MOUNTED ON THE HOUSINGS

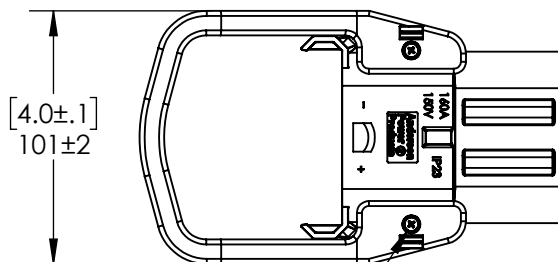
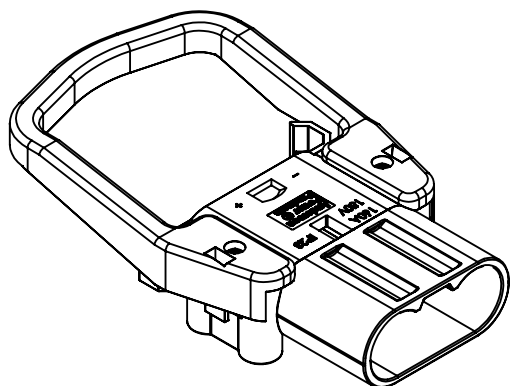

(2) SELF-TAPPING SCREWS

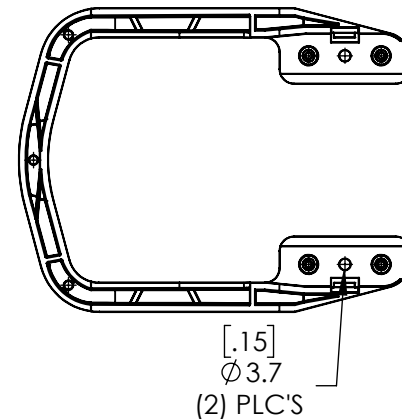
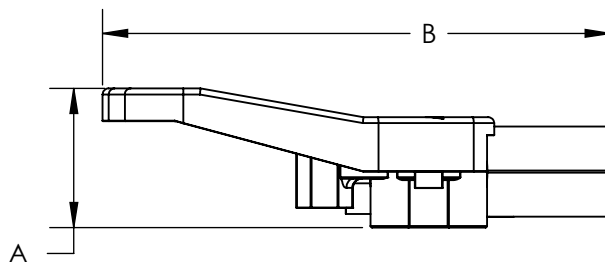
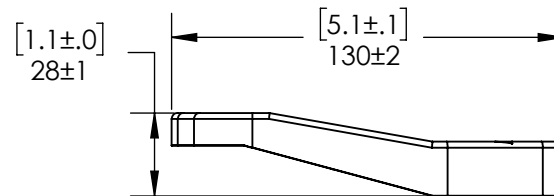

DIM	A		B	
	mm ±1	IN ±.04	mm ±2	IN ±.1
ON 160	47.0	1.85	169	6.7
ON 320	54.5	2.15	175	6.9

NOTES:

- KIT INCLUDES HANDLE AND (2) SELF-TAPPING SCREWS
- FOR USE WITH 160A & 320A CONNECTORS

PART NO.	DESCRIPTION	COLOR	MATERIAL
E160-89	160/320 HANDLE KIT	GRAY	PBT-PC BLEND
16-89	160/320 HANDLE KIT	BLACK	NYLON

REV.	DESCRIPTION	APPRV	DATE
3	ECN 2016-0117	CMS	12/13/2016
2	ECRN 14064- UPDATE CATALOG NUMBERS	AMS	10/11/06
1	ECRN 13995 INCORRECT P/N LISTED	AMS	04/24/06

REVISIONS

DIMENSIONS ARE IN:	MM [INCH]	APPROVALS		<p>ANDERSON POWER PRODUCTS</p> <p>TITLE</p> <p>SALES OUTLINE LOW PROFILE HANDLE FOR 160A AND 320A CONNECTORS</p>
UNLESS OTHERWISE STATED		DRAWN	1/20/2006	
TOLERANCES:		CHECKED	1/20/2006	
DECIMALS (INCH) DECIMALS (MM) ANGLES		PM APPRV	1/19/2006	
.XX ±.02 .X ±.5 ±2°		CHB	1/19/2006	
SURFACE FINISH:		QC APPRV	1/20/2006	
MACHINED 3.2µ [128µin]		UFN	1/20/2006	
MOLDED 1.6µ [64µin]		ENG APPRV	1/19/2006	
MATERIAL: SEE DATA SHEETS FOR MATERIAL SPECS		DAM	1/19/2006	
FINISH:		SIZE	DWG NO.	REV.
		A	E160-8S1	3
-CAD GENERATED DRAWING- DO NOT MANUALLY UPDATE DO NOT SCALE		SCALE	CADFILE	SHEET
		NONE	02497	1 OF 1