

THE INFORMATION CONTAINED IN THIS DRAWING IS THE SOLE PROPERTY OF ANDERSON POWER PRODUCTS. ANY REPRODUCTION IN PART OR WHOLE WITHOUT THE WRITTEN PERMISSION OF ANDERSON POWER PRODUCTS IS PROHIBITED.

Copyright 2017

ANDERSON POWER PRODUCTS RESERVES THE RIGHT TO ALTER PRODUCT TYPES, THEIR TECHNICAL DATA, DIMENSION, STYLE AND ACCESSORIES WITHOUT PRIOR NOTIFICATION.

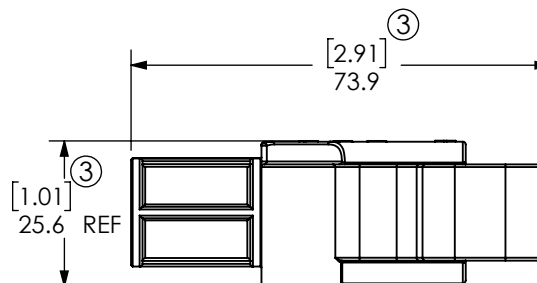
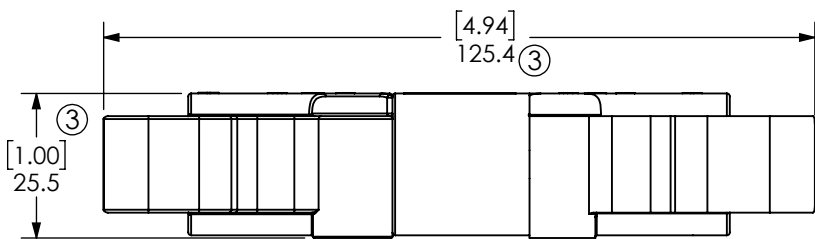
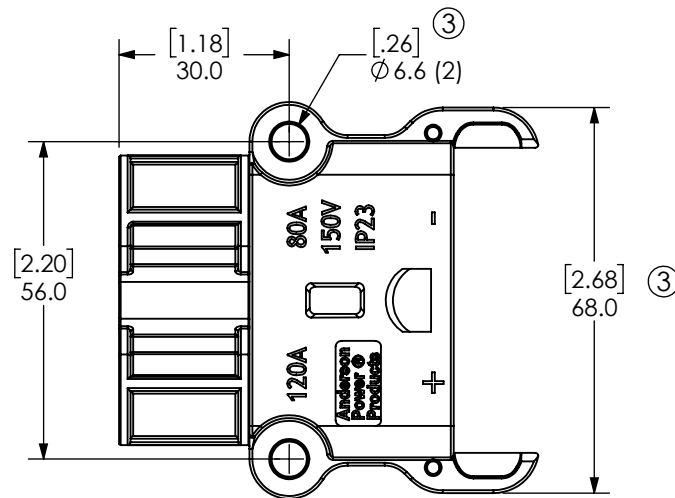
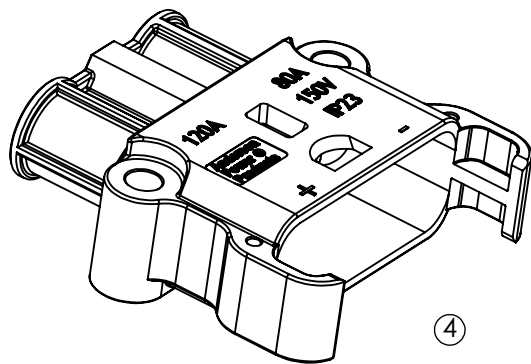

MATED PAIR

PART NO.	DESCRIPTION	MATERIAL	COLOR
80-2	ABC SOCKET HSG. (80A)	NYLON	BLACK
EP80-2	EBC SOCKET HSG. (80A)	PBT-PC BLEND	BLACK

④

DIMENSIONS ARE IN:	INCH [MM]	APPROVALS		 ANDERSON POWER PRODUCTS	
UNLESS OTHERWISE STATED		DRAWN	AMP 6/7/2005		TITLE SALES OUTLINE 80A FEMALE SOCKET HOUSING
TOLERANCES:		CHECKED	DJD 6/9/2005		
DECIMALS (INCH) DECIMALS (MM) ANGLES .XX ± .015 .X ± .38 ±.5° .XXX ± .005 .XX ± .13		MFG APPRV	CHB 6/7/2005		
SURFACE FINISH: MACHINED 128µin [3.2µ] MOLDED 64µin [1.6µ]		QC APPRV	JJA 6/9/2005		
MATERIAL:		ENG APPRV	DAM 6/8/2005	SIZE	
SEE TABLE				DWG NO.	
FINISH:				REV.	
		-CAD GENERATED DRAWING- DO NOT MANUALLY UPDATE DO NOT SCALE		SCALE	
				CADFILE	
				SHEET	
				0.75:1	
				02360	
				1 OF 1	

REV.	DESCRIPTION	APPRV	DATE
4	ECN 2023-0042 - VDE, EN1175 CURRENT RATING	CPD	5/30/2023
3	ECN 2016-0096 - GEOMETRY UPDATED	CMS	1/18/2017
2	ECRN 14292- REMOVE "E" & "EN" SERIES PART NUMBERS	AMS	7/25/08
1	ECRN 13946- ADD "EP" & "EN" SERIES PART NUMBERS	AMS	01/19/06
REVISIONS			