

THE INFORMATION CONTAINED IN THIS DRAWING IS THE SOLE PROPERTY OF ANDERSON POWER PRODUCTS. ANY REPRODUCTION IN PART OR WHOLE WITHOUT THE WRITTEN PERMISSION OF ANDERSON POWER PRODUCTS IS PROHIBITED.

Copyright 2006

ANDERSON POWER PRODUCTS RESERVES THE RIGHT TO ALTER PRODUCT TYPES, THEIR TECHNICAL DATA, DIMENSION, STYLE AND ACCESSORIES WITHOUT PRIOR NOTIFICATION.

THESE DIMENSIONS SHOWN WITH THE HANDLE MOUNTED ON THE HOUSINGS

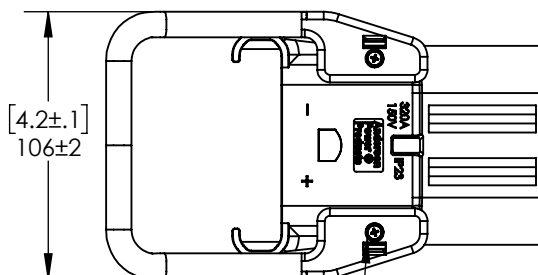
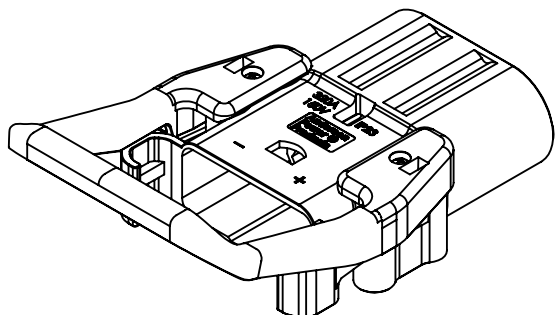

(2) SELF-TAPPING SCREWS

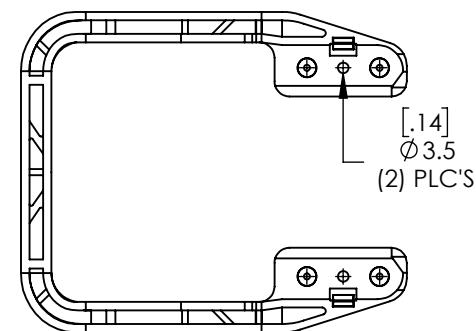
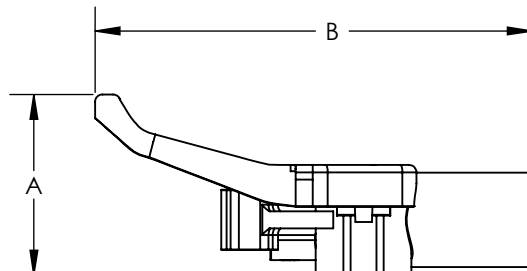
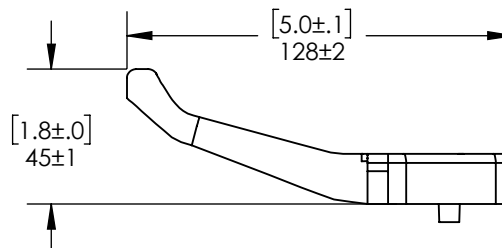

DIM	A		B	
	mm ±1	IN ±.04	mm ±2	IN ±.1
ON 160	63.5	2.50	168	6.6
ON 320	71.0	2.80	174	6.9

PART NO.	DESCRIPTION	COLOR	MATERIAL
E320-89	160/320 HANDLE KIT	GRAY	PBT-PC BLEND
32-89	160/320 HANDLE KIT	BLACK	NYLON

NOTES:

- KIT INCLUDES HANDLE AND (2) SELF-TAPPING SCREWS
- FOR USE WITH 160A & 320A CONNECTORS

REV.	DESCRIPTION	APPRV	DATE
3	ECN 2016-0117	CMS	12/13/16
2	ECRN 14064- UPDATE CATALOG NUMBERS	AMS	10/11/06
1	ECRN 14051: UPDATER PER ISIR 06-096 & 06-006A	AMS	8/18/06
REVISIONS			

DIMENSIONS ARE IN:	MM [INCH]	APPROVALS		<p>ANDERSON POWER PRODUCTS</p> <p>TITLE</p> <p>SALES OUTLINE HIGH PROFILE HANDLE FOR 160A & 320A CONNECTORS</p>
UNLESS OTHERWISE STATED		DRAWN	4/25/2006	
TOLERANCES:		CHECKED	4/25/2006	
DECIMALS (INCH)	DECIMALS (MM)	ANGLES		
.XX ±.02	.X ±.5	±2°		
SURFACE FINISH:		PM APPRV	4/25/2006	
MACHINED 3.2µ [128µin]		CHB		
MOLDED 1.6µ [64µin]		QC APPRV	4/25/2006	
MATERIAL: SEE DATA SHEETS FOR MATERIAL SPECS		HN	4/25/2006	
FINISH:		ENG APPRV	4/25/2006	
		DAM		
		-CAD GENERATED DRAWING- DO NOT MANUALLY UPDATE DO NOT SCALE	SIZE A	DWG NO. E320-8S1
			SCALE NONE	REV. 3
			CADFILE 02525	SHEET 1 OF 1