

THE INFORMATION CONTAINED IN THIS DRAWING IS THE SOLE PROPERTY OF ANDERSON POWER PRODUCTS. ANY REPRODUCTION IN PART OR WHOLE WITHOUT THE WRITTEN PERMISSION OF ANDERSON POWER PRODUCTS IS PROHIBITED.

Copyright 2009

ANDERSON POWER PRODUCTS RESERVES THE RIGHT TO ALTER PRODUCT TYPES, THEIR TECHNICAL DATA, DIMENSION, STYLE AND ACCESSORIES WITHOUT PRIOR NOTIFICATION.

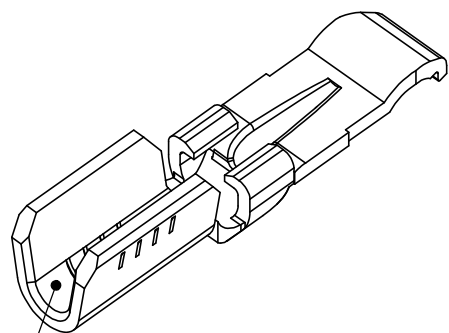

BARREL SIZED FOR #16-20 AWG WIRE

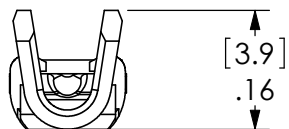

[3.6]
.14

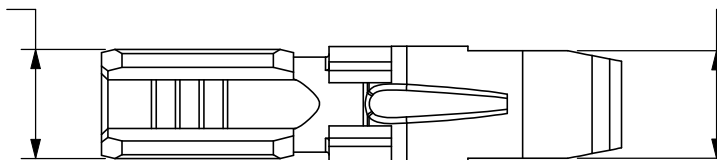

[3.6]
.14

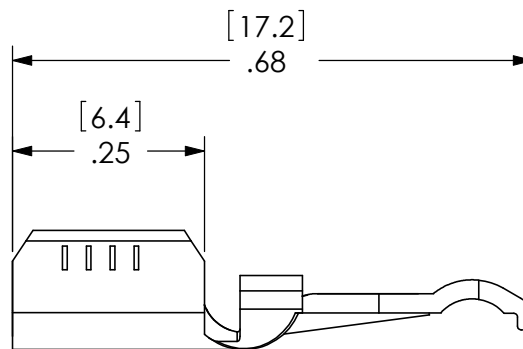

DIMENSIONS ARE IN: INCH[MM]		APPROVALS		ANDERSON POWER PRODUCTS	
UNLESS OTHERWISE STATED		DRAWN	PMS 04/08/80	TITLE CAT. NO. 262G1 PP15 REEL CONTACT FOR TYPE "F" CRIMP	
TOLERANCES:		CHECKED	LVR 04/08/80		
DECIMALS (INCH)	DECIMALS (MM)	ANGLES	MFG APP		
.XX ±.02	.X ±.5	±2°	LMP 04/08/80		
SURFACE FINISH:		QC APP		ENG APP	
MACHINED	128 [3.2]			HHR 04/08/80	
MOLDED	64 [1.6]				
MATERIAL:		SIZE	A/A4	DWG NO.	112718S2
FINISH:		SCALE	NONE	REV.	4
HOT TIN DIP		CADFILE	01035	SHEET	1 OF 1

4	ECRN 14433 - CORRECT WIDTH OF CRIMP WINGS FROM .18" TO .14"	AMS	05/19/09
REV.	DESCRIPTION OF CHANGES	APPROVED	DATE



-CAD GENERATED DRAWING-
DO NOT MANUALLY UPDATE
DO NOT SCALE

SCALE NONE
DWG NO. 112718S2
REV. 4
SHEET 1 OF 1