

THE INFORMATION CONTAINED IN THIS DRAWING IS THE SOLE PROPERTY OF ANDERSON POWER PRODUCTS. ANY REPRODUCTION IN PART OR WHOLE WITHOUT THE WRITTEN PERMISSION OF ANDERSON POWER PRODUCTS IS PROHIBITED.

Copyright 2009

ANDERSON POWER PRODUCTS RESERVES THE RIGHT TO ALTER PRODUCT TYPES, THEIR TECHNICAL DATA, DIMENSION, STYLE AND ACCESSORIES WITHOUT PRIOR NOTIFICATION.

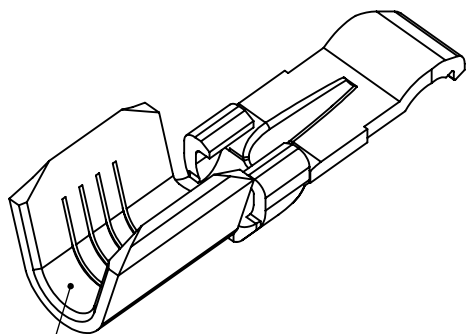

BARREL FOR  
#10-14 AWG WIRE

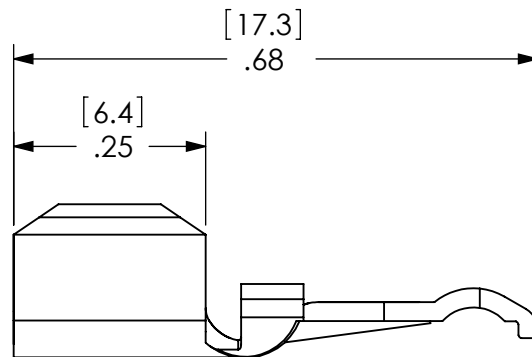
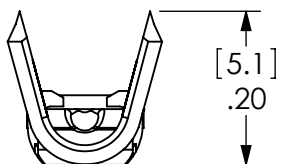
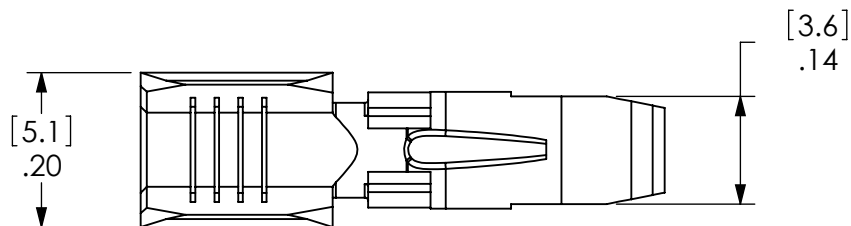

DIMENSIONS ARE IN:	INCH[MM]
UNLESS OTHERWISE STATED	
TOLERANCES:	
DECIMALS (INCH)	DECIMALS (MM) ANGLES
.XX ± .02	.X ± .5 ±2°
SURFACE FINISH:	
MACHINED	128 [3.2] ✓
MOLDED	64 [1.6] ✓
MATERIAL: COPPER	
FINISH: SILVER PLATE	

APPROVALS	
DRAWN	NTS 6/18/09
CHECKED	DJD 6/18/09
MFG APP	CHB 6/18/09
QC APP	UFN 6/18/09
ENG APP	BD 6/18/09

ANDERSON POWER PRODUCTS	
TITLE	CATALOG #261G3 PP45 REEL CONTACT TYPE "F" CRIMP
SIZE	A/A4
DWG NO.	112718S7
REV.	0

*****	*****	*****	*****
REV.	DESCRIPTION OF CHANGES	APPROVED	DATE



-CAD GENERATED DRAWING-  
DO NOT MANUALLY UPDATE  
DO NOT SCALE

SCALE	NONE	CADFILE	02926	SHEET	1 OF 1
-------	------	---------	-------	-------	--------