

8 7 6 5 4 3 2 1

THE INFORMATION CONTAINED IN THIS DRAWING IS THE SOLE PROPERTY OF ANDERSON POWER PRODUCTS. ANY REPRODUCTION IN PART OR WHOLE WITHOUT THE WRITTEN PERMISSION OF ANDERSON POWER PRODUCTS IS PROHIBITED.

**Copyright 1999**

ANDERSON POWER PRODUCTS RESERVES THE RIGHT TO ALTER PRODUCT TYPES, THEIR TECHNICAL DATA, DIMENSION, STYLE AND ACCESSORIES WITHOUT PRIOR NOTIFICATION.

D  
C  
B  
A

D  
C  
B  
A

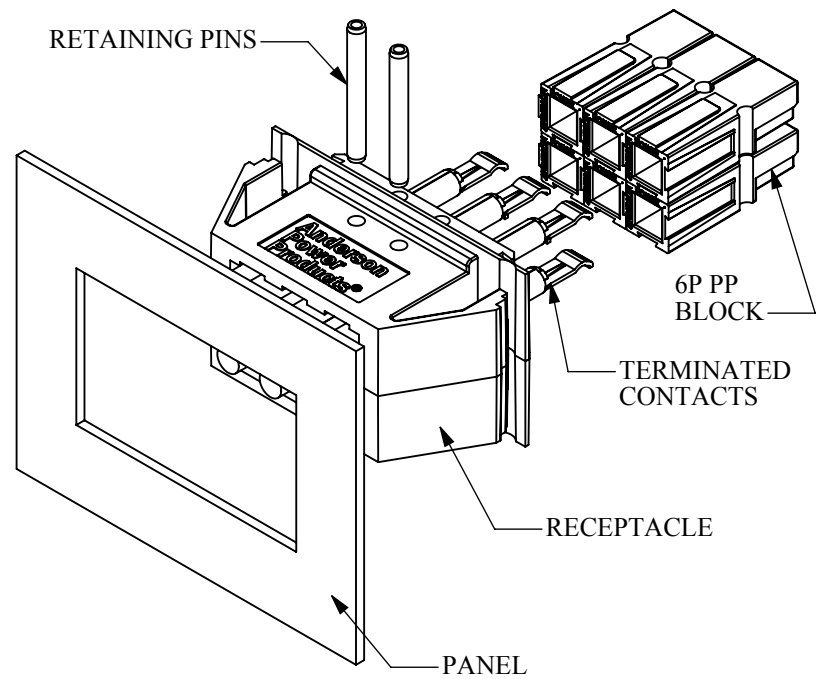
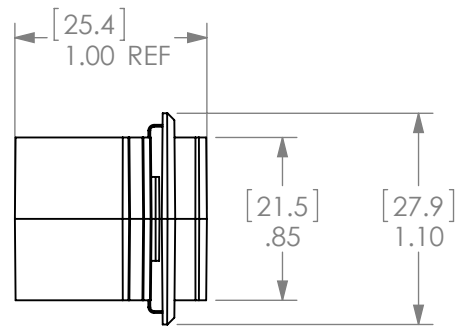
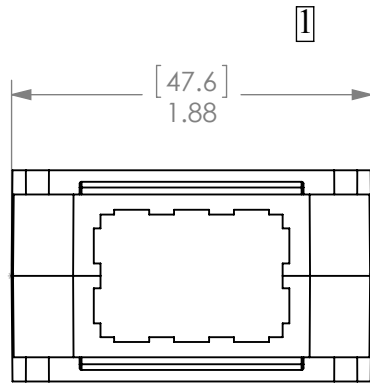
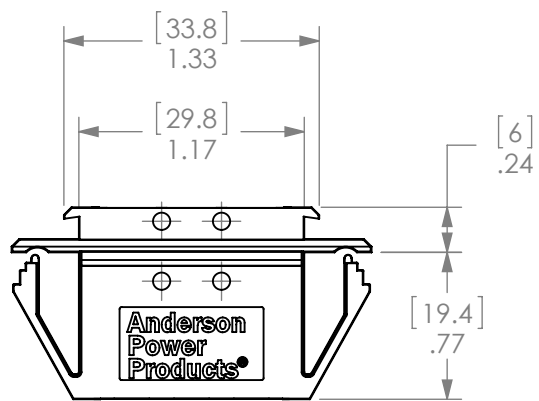

TYPICAL ASSEMBLY- REFER TO CATALOG FOR AVAILABLE CONFIGURATIONS

**NOTES:**

- DESIGNED FOR PANELS .030-.134" (.76-3.4mm) THICK
- KNOCKOUT SIZE 1.00 X 1.62 (25.4 X 41.1)

|                         |  |               |  |                  |     |                                |   |
|-------------------------|--|---------------|--|------------------|-----|--------------------------------|---|
| DIMENSIONS ARE IN:      |  | INCH [MM]     |  | <i>APPROVALS</i> |     | <b>ANDERSON POWER PRODUCTS</b> |   |
| UNLESS OTHERWISE STATED |  |               |  | DRAWN            | CMS | 8/6/1999                       | TITLE<br>CATALOG NUMBER 1470G2<br>2X3 POWERPOLE PAK<br>SNAP-IN RECEPTACLE |
| TOLERANCES:             |  |               |  | CHECKED          | DJD | 8/9/1999                       |   |
| DECIMALS (INCH)         |  | DECIMALS (MM) |  | MFG APPRV        |     |                                |   |
| .XX ± .02               |  | .X ± .5       |  | CHB              |     | 8/23/1999                      |   |
|                         |  | ANGLES ±2°    |  | QC APPRV         |     |                                |   |
| SURFACE FINISH:         |  |               |  | RO               |     | 8/24/1999                      |   |
| MACHINED                |  | 128µin [3.2µ] |  | ENG APPRV        |     |                                | SIZE  |
| MOLDED                  |  | 64µin [1.6µ]  |  | UFN              |     | 8/24/1999                      | DWG NO.   |
| MATERIAL: POLYCARBONATE |  |               |  |                  |     |                                | REV.  |
| FINISH: NONE            |  |               |  |                  |     |                                | 1   |
| 3rd ANGLE PROJECTION    |  |               |  |                  |     |                                | SCALE   |
|                         |  |               |  |                  |     |                                | NONE  |
|                         |  |               |  |                  |     |                                | CADFILE   |
|                         |  |               |  |                  |     |                                | 01095   |
|                         |  |               |  |                  |     |                                | SHEET   |
|                         |  |               |  |                  |     |                                | 1 OF 1  |

|           |             |       |           |
|-----------|-------------|-------|-----------|
| 1         | ECRN-15527  | TWE   | 12/5/2013 |
| REV.      | DESCRIPTION | APPRV | DATE      |
| REVISIONS |             |       |           |

8 7 6 5 4 3 2 1