

THE INFORMATION CONTAINED IN THIS DRAWING IS THE SOLE PROPERTY OF ANDERSON POWER PRODUCTS. ANY REPRODUCTION IN PART OR WHOLE WITHOUT THE WRITTEN PERMISSION OF ANDERSON POWER PRODUCTS IS PROHIBITED.

Copyright 2015

ANDERSON POWER PRODUCTS RESERVES THE RIGHT TO ALTER PRODUCT TYPES, THEIR TECHNICAL DATA, DIMENSION, STYLE AND ACCESSORIES WITHOUT PRIOR NOTIFICATION.

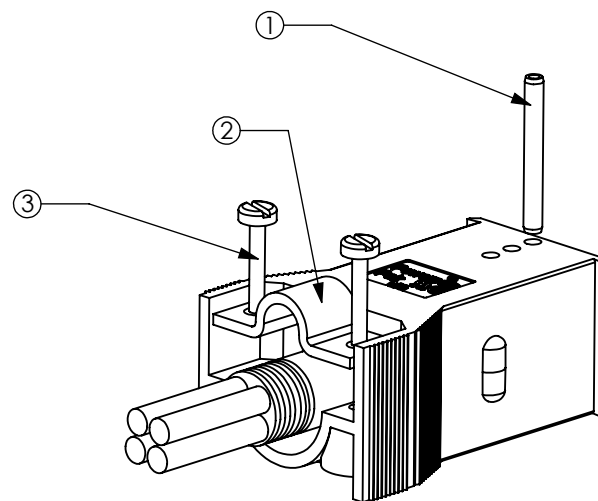
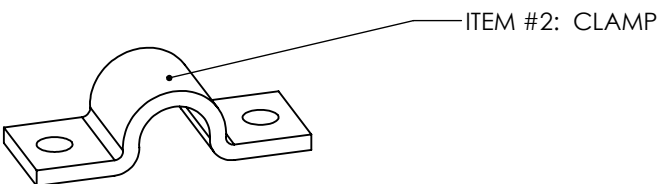
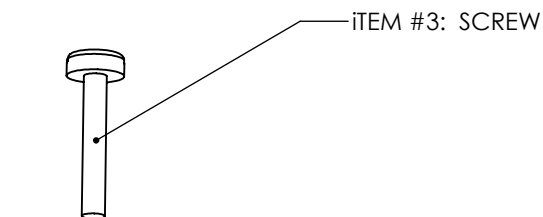
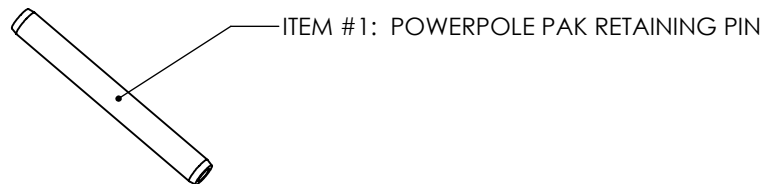

NOTE:
1. COMPATIBLE WITH PLUG SHELL PART NUMBERS:
1460G23 AND 1461G23

ITEM	QTY	PART #	DESCRIPTION
1	1	110G9-BK	POWERPOLE PAK-RETAINING PIN
2	1	112019P1	CLAMP
3	2	H1120P39	#4 X 1/2 LONG SELF TAPPING SCREW

DIMENSIONS ARE IN:	INCH [MM]	APPROVALS		ANDERSON POWER PRODUCTS TITLE SALES OUTLINE FOR CABLE CLAMP HDWR BAG 115G7-BK
UNLESS OTHERWISE STATED		DRAWN	TWE 8/24/2015	
TOLERANCES:		CHECKED	CMS 8/25/2015	
DECIMALS (INCH)	DECIMALS (MM)	ANGLES		
.XX ± .02	.X ± .5	±2°		
SURFACE FINISH:		MFG APPRV	CHB 8/25/2015	
MACHINED	128µin [3.2µ]	QC APPRV	UFN 8/25/2015	
MOLDED	64µin [1.6µ]	ENG APPRV	CLY 8/25/2015	
MATERIAL:		SIZE	A	DWG NO.
N/A		REV.	0	115459S1
FINISH:		SCALE	NONE	CADFILE
				04624
				SHEET
				1 OF 1

REV.	DESCRIPTION	APPRV	DATE
REVISIONS			