

THE INFORMATION CONTAINED IN THIS DRAWING IS THE SOLE PROPERTY OF ANDERSON POWER PRODUCTS. ANY REPRODUCTION IN PART OR WHOLE WITHOUT THE WRITTEN PERMISSION OF ANDERSON POWER PRODUCTS IS PROHIBITED.

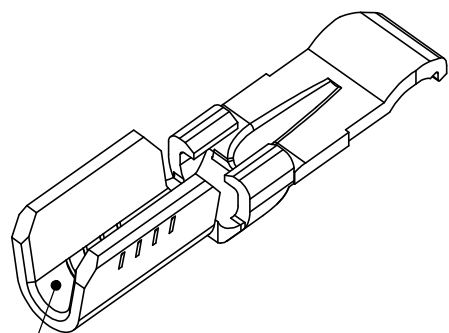

Copyright 2009

ANDERSON POWER PRODUCTS RESERVES THE RIGHT TO ALTER PRODUCT TYPES, THEIR TECHNICAL DATA, DIMENSION, STYLE AND ACCESSORIES WITHOUT PRIOR NOTIFICATION.

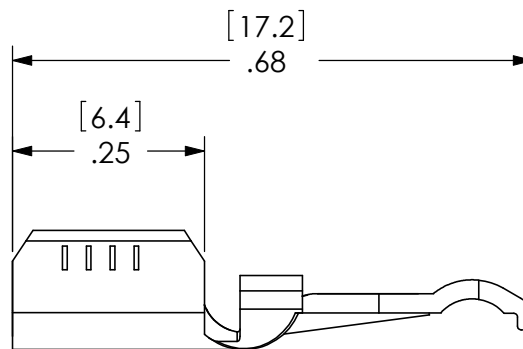
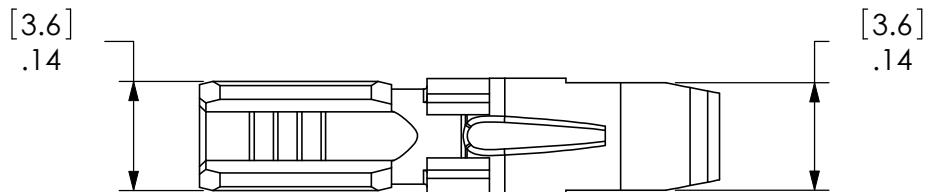
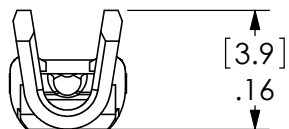

BARREL SIZED FOR #16-20 AWG WIRE



DIMENSIONS ARE IN: INCH[MM]		APPROVALS		ANDERSON POWER PRODUCTS	
UNLESS OTHERWISE STATED		DRAWN	PMS 04/08/80	 TITLE CAT. NO. 262G1 PP15 REEL CONTACT FOR TYPE "F" CRIMP	
TOLERANCES:		CHECKED	LVR 04/08/80		
DECIMALS (INCH)	DECIMALS (MM)	MFG APP	LMP 04/08/80		
.XX ±.02	.X ±.5	QC APP			
ANGLES ±2°		ENG APP	HHR 04/08/80	SIZE	A/A4
SURFACE FINISH:				DWG NO.	112718S2
MACHINED 128 [3.2] ✓				REV.	4
MOLDED 64 [1.6] ✓				SCALE	NONE
MATERIAL:				CADFILE	01035
COPPER ALLOY				SHEET	1 OF 1
FINISH:					
HOT TIN DIP					
		-CAD GENERATED DRAWING- DO NOT MANUALLY UPDATE DO NOT SCALE			

4	ECRN 14433 - CORRECT WIDTH OF CRIMP WINGS FROM .18" TO .14"	AMS	05/19/09
REV.	DESCRIPTION OF CHANGES	APPROVED	DATE