

THE INFORMATION CONTAINED IN THIS DRAWING IS THE SOLE PROPERTY OF ANDERSON POWER PRODUCTS. ANY REPRODUCTION IN PART OR WHOLE WITHOUT THE WRITTEN PERMISSION OF ANDERSON POWER PRODUCTS IS PROHIBITED.

Copyright 2009

ANDERSON POWER PRODUCTS RESERVES THE RIGHT TO ALTER PRODUCT TYPES, THEIR TECHNICAL DATA, DIMENSION, STYLE AND ACCESSORIES WITHOUT PRIOR NOTIFICATION.

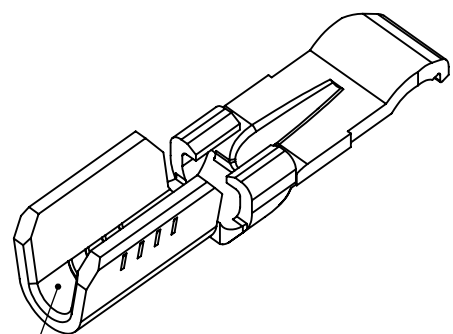

BARREL SIZED FOR #16-20 AWG WIRE

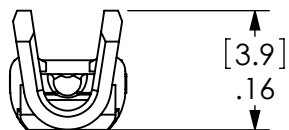

[3.9]  
.16

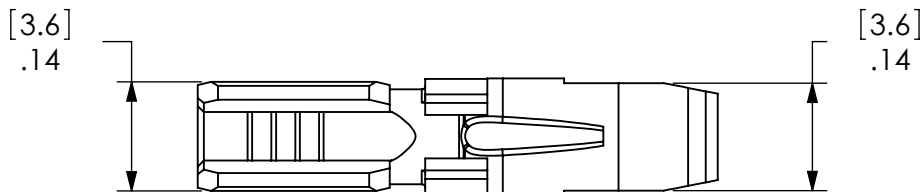

[3.6]  
.14

[3.6]  
.14

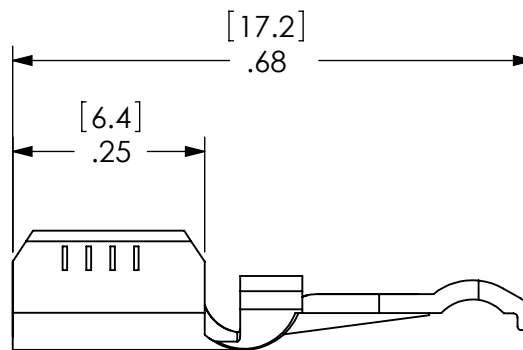

[17.2]  
.68

[6.4]  
.25

DIMENSIONS ARE IN: INCH[MM]		APPROVALS		<b>ANDERSON POWER PRODUCTS</b>
UNLESS OTHERWISE STATED		DRAWN	NTS 6/18/09	
TOLERANCES:		CHECKED	DJD 6/18/09	SIZE A/A4
DECIMALS (INCH)	DECIMALS (MM)	ANGLES	MFG APP	
.XX ± .02	.X ± .5	±2°	CHB 6/18/09	REV. 0
SURFACE FINISH:		MATERIAL:	QC APP	
MACHINED	128 [3.2]	COPPER ALLOY	UFN 6/18/09	CADFILE 02927
MOLDED	64 [1.6]	FINISH:	ENG APP	
SILVER PLATE		-CAD GENERATED DRAWING- DO NOT MANUALLY UPDATE DO NOT SCALE		

REV.	DESCRIPTION OF CHANGES	APPROVED	DATE
8			
7			
6			
5			



8

7

6

5

4

3

2

1