

8 7 6 5 4 3 2 1

THE INFORMATION CONTAINED IN THIS DRAWING IS THE SOLE PROPERTY OF ANDERSON POWER PRODUCTS. ANY REPRODUCTION IN PART OR WHOLE WITHOUT THE WRITTEN PERMISSION OF ANDERSON POWER PRODUCTS IS PROHIBITED.

ANDERSON POWER PRODUCTS RESERVES THE RIGHT TO ALTER PRODUCT TYPES, THEIR TECHNICAL DATA, DIMENSION, STYLE AND ACCESSORIES WITHOUT PRIOR NOTIFICATION.

REV.	DESCRIPTION OF CHANGES	BY:	DATE
2	ECRN 13223: REDRAWN	CMS	6/29/99
3	ECRN 13433	CMS	10/23/01

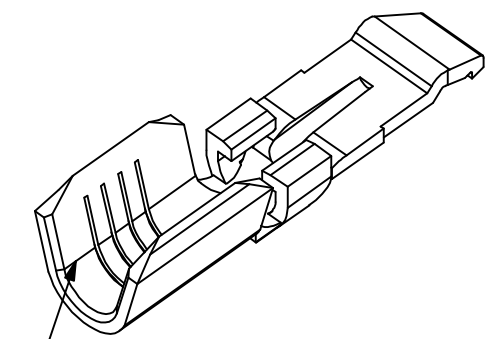
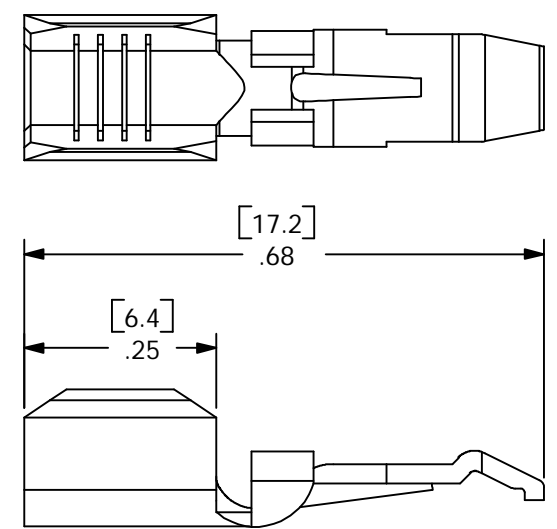
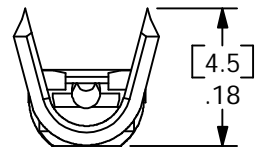
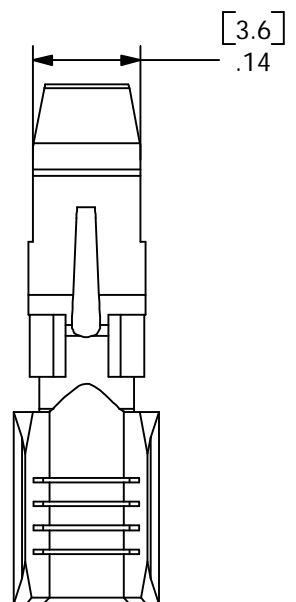

FOR #12-16 WIRE

D C B A

A

8 7 6 5 4 3 2 1

ITEM NO.	PART OR IDENTIFYING NO.	NOMENCLATURE OR DESCRIPTION	MATERIAL SPECIFICATION	QTY REQD
COPYRIGHT 1999 ANDERSON POWER PRODUCTS. ALL RIGHTS RESERVED. UNAUTHORIZED REPRODUCTION HEREBY PROHIBITED.				
DIMENSIONS ARE IN INCHES DIMENSIONS IN PARENTHESES [] ARE IN MILLIMETERS		CAD GENERATED DRAWING, DO NOT MANUALLY UPDATE		
TOLERANCES ARE: 2PL- ±.02 [±.5]		APPROVALS DATE		
MATERIALS: <i>COPPER</i>		DRAWN RLE 9/9/97		
FINISH <i>HOT TIN DIP</i>		CHECKED DJD 10/9/01		
NEXT ASSY USED ON		RESP ENG UFN 9/10/97		
APPLICATION		MFG ENG CHB 10/21/01		
DO NOT SCALE DRAWING		QUAL ENG DJM 9/18/97		
		SPECIFICATION: 113967S1		REV. 3
		SCALE NONE CADFILES/01061		SHEET 1 OF 1

ANDERSON POWER PRODUCTS
CATALOG NUMBER 269G1
15-45 AMP HIGH DETENT CONTACT
FOR REEL TYPE "F" CRIMP
#12-16 WIRE