

THE INFORMATION CONTAINED IN THIS DRAWING IS THE SOLE PROPERTY OF ANDERSON POWER PRODUCTS. ANY REPRODUCTION IN PART OR WHOLE WITHOUT THE WRITTEN PERMISSION OF ANDERSON POWER PRODUCTS IS PROHIBITED.

Copyright 2008

ANDERSON POWER PRODUCTS RESERVES THE RIGHT TO ALTER PRODUCT TYPES, THEIR TECHNICAL DATA, DIMENSION, STYLE AND ACCESSORIES WITHOUT PRIOR NOTIFICATION.

8 7 6 5 4 3 2 1

E

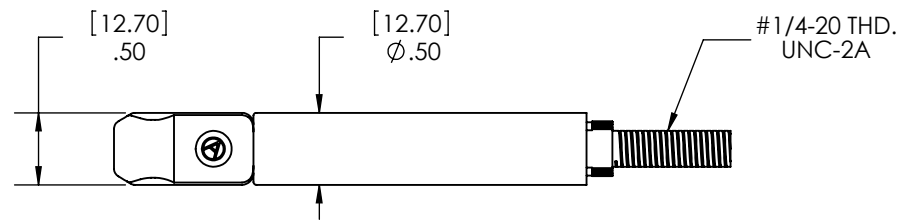

180BBS SHOWN AS EXAMPLE

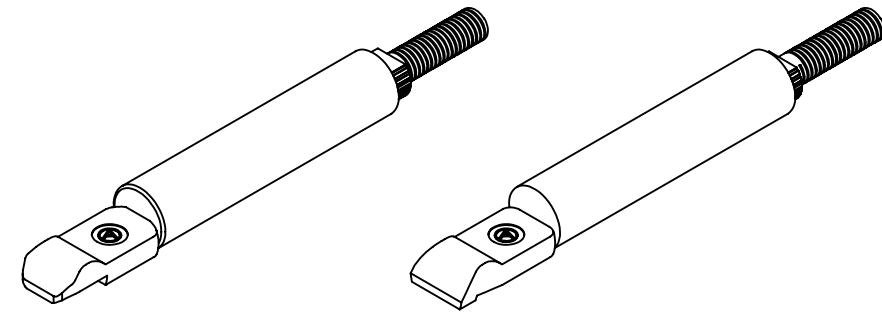

D

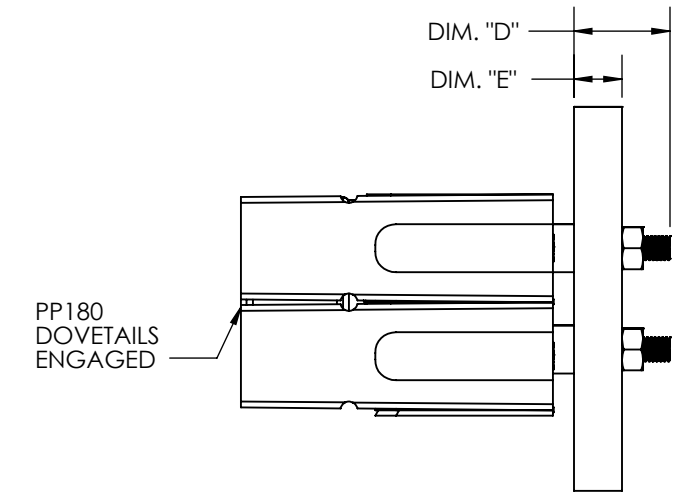
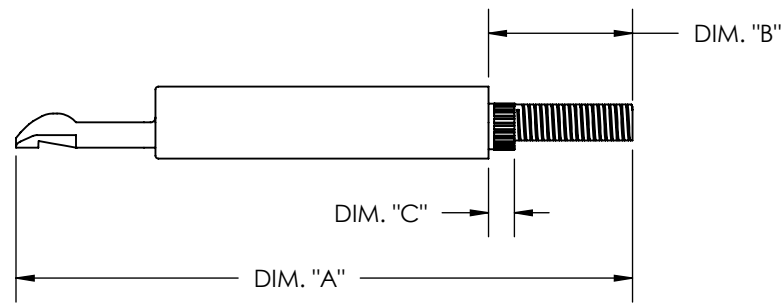

C

NOTES:

1. TIGHTENING TORQUE = 70 IN-LBS.
2. CONTACT MATERIAL = COPPER ALLOY
FINISH = SILVER PLATE
HOUSING MATERIAL = POLYCARBONATE
3. #1/4-20 NUT INCLUDED WITH CONTACT
4. ASSUMES DOVETAILS WILL BE ENGAGED FOR PP ASSEMBLIES

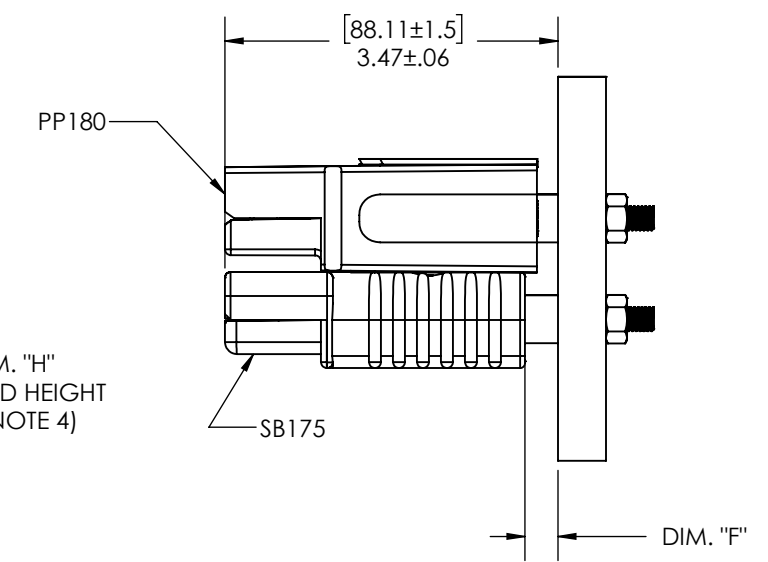
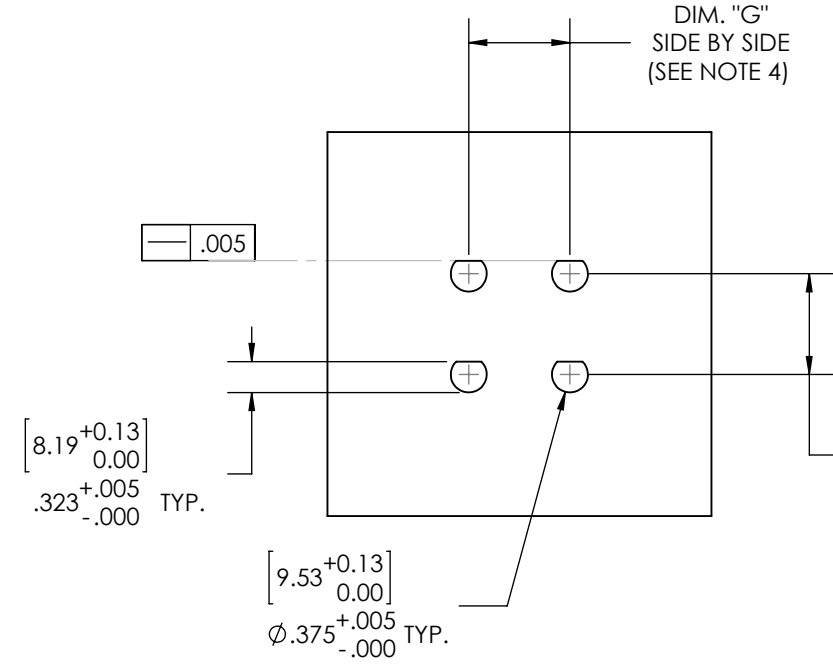

B

CONTACT	DIM. "A"		DIM. "B"		DIM. "C"		DIM. "D"		DIM. "E" MIN.		DIM. "E" MAX.	
	INCH	MM	INCH	MM	INCH	MM	INCH	MM	INCH	MM	INCH	MM
180BBS	4.29±.030	109.0±.75	1.00	25.4	0.180±.010	4.57±.25	1.00	25.4	0.195	4.95	0.750	19.05
114733G1	4.29±.030	109.0±.75	1.02	25.8	0.127±.010	3.23±.25	1.02	25.8	0.142	3.61	0.750	19.05
114870G1	4.29±.030	109.0±.75	1.00	25.4	0.100±.010	2.54±.25	1.00	25.4	0.115	2.92	0.750	19.05

A

HOUSING	DIM. "F"		DIM. "G"		DIM. "H"	
	INCH	MM	INCH	MM	INCH	MM
PP180	0.22	5.6	1.125±.005	28.58±.13	1.125±.005	28.58±.005
SB175	0.34	8.6	1.054±.005	26.77±.13	1.05 MIN.	26.7 MIN.

REV.	DESCRIPTION OF CHANGES	APPROVED	DATE
7	ECN 2023-0029 - 70 IN-LBS WAS 35 IN-LBS	CPD	4/10/2023
6	ECRN-14949 CONSOLIDATE TO ACTIVE PARTS ON OUTLINE & MANUFACTURING DRWGS	CMS	7/25/11
5	ECRN 14618 - ADDED TOLERANCING IN TABLE/ ADDED TORQUE	LLD	05/04/10
4	ECRN 14435 - UPDATE TABLE FOR 114733G1	AMS	05/27/09
3	ECRN 14429 - TIGHTEN TOLERANCES IN CONTACT TABLE	AMS	05/07/09
2	ECRN 14425 - ADD 114870G1 TO TABLE	AMS	04/30/09
1	ECRN 14308 - REVISE & REDRAW	AMS	08/28/08

DIMENSIONS ARE IN:			APPROVALS	
INCH	[MM]		DRAWN	LH 07/26/07
UNLESS OTHERWISE STATED			CHECKED	EB 07/26/07
TOLERANCES:			MFG APP	CHB 07/26/07
DECIMALS (INCH)	DECIMALS (MM)	ANGLES	QC APP	MC 07/26/07
.XX ±.02	.X ±.5	±2°	ENG APP	MOD 07/26/07
SURFACE FINISH:				
MACHINED 128 [3.2]				
MOLDED 64 [1.6]				
MATERIAL: SEE NOTE 2				
FINISH: SEE NOTE 2				
-CAD GENERATED DRAWING- DO NOT MANUALLY UPDATE DO NOT SCALE				

ANDERSON POWER PRODUCTS

TITLE: SALES OUTLINE FOR PP180/SB175 BUS CONTACTS

SIZE: B/A3 DWG NO.: B02043S1 REV.: 7

SCALE: NONE CADFILE: 02704 SHEET: 1 OF 1

8 7 6 5 4 3 2 1

E

D

C

B

A