

THE INFORMATION CONTAINED IN THIS DRAWING IS THE SOLE PROPERTY OF ANDERSON POWER PRODUCTS. ANY REPRODUCTION IN PART OR WHOLE WITHOUT THE WRITTEN PERMISSION OF ANDERSON POWER PRODUCTS IS PROHIBITED.

Copyright 2009

ANDERSON POWER PRODUCTS RESERVES THE RIGHT TO ALTER PRODUCT TYPES, THEIR TECHNICAL DATA, DIMENSION, STYLE AND ACCESSORIES WITHOUT PRIOR NOTIFICATION.

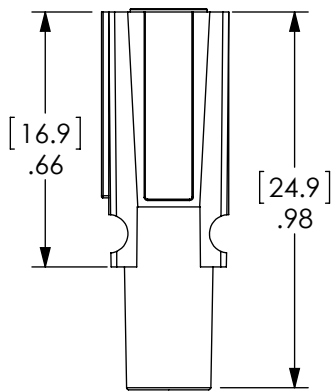

DOVETAILS ALLOW STACKING IN VERTICAL, HORIZONTAL, OR IN BLOCK CONFIGURATIONS.

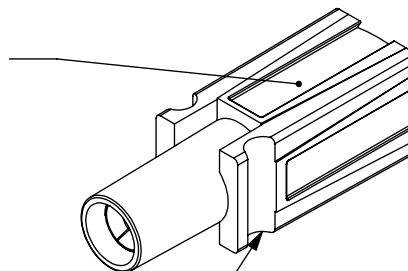

WHEN MATED SIDE TO SIDE, HALF-ROUNDS ALIGN TO FORM A SLOT FOR ROLL PIN INSERTION, WHICH PROTECTS AGAINST ACCIDENTAL DISLODGING OF MATED HOUSINGS.

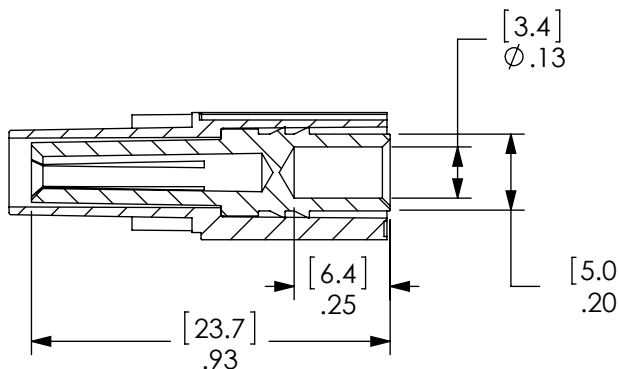
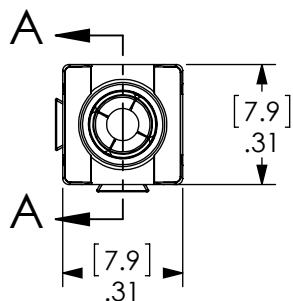

ORDERING INFORMATION FOR CONTACT/HOUSING SETS

CAT. NO.	PLATING
PP30MF-S10T	TIN
PP30MF-S10S	SILVER

NOTES:

- CONTACT MUST BE CRIMPED ONTO WIRE BEFORE CONTACT IS INSERTED INTO THE HOUSING
- MATERIALS - HOUSING: POLYCARBONATE
CONTACT: COPPER ALLOY

REV.	DESCRIPTION	APPRV	DATE
4	ECRN-15089 UPDATED	TWE	3/16/12
3	ECRN-13484 ADD CAT. NO. TABLE	CMS	05/15/02
2	ECRN-13433	CMS	10/23/01
1	ECRN-13287 ADD CRIMP NOTE	CMS	01/13/00

REVISIONS

DIMENSIONS ARE IN:	INCH [MM]	APPROVALS		<p>ANDERSON POWER PRODUCTS</p> <p>TITLE</p> <p>POWERPOLE 30 GROUND SOCKET MAKE-FIRST-BREAK LAST</p>
UNLESS OTHERWISE STATED		DRAWN	1/25/1999	
TOLERANCES:		CMS		
DECIMALS (INCH)	DECIMALS (MM)	CHECKED	1/26/1999	
.XX ± .02	.X ± .5	ANGLES ±2°		
SURFACE FINISH:		MFG APPRV	10/21/2001	
MACHINED 128µin [3.2µ]		CHB		
MOLDED 64µin [1.6µ]		QC APPRV	10/10/2001	
MATERIAL: SEE NOTE 2		RPO		
FINISH: SEE TABLE		ENG APPRV	10/22/2001	
		UFN		SIZE A DWG NO. 113920S2 REV. 4
<p>3rd ANGLE PROJECTION</p>		-CAD GENERATED DRAWING- DO NOT MANUALLY UPDATE DO NOT SCALE		SCALE NONE CADFILE 01127 SHEET 1 OF 1