

THE INFORMATION CONTAINED IN THIS DRAWING IS THE SOLE PROPERTY OF ANDERSON POWER PRODUCTS. ANY REPRODUCTION IN PART OR WHOLE WITHOUT THE WRITTEN PERMISSION OF ANDERSON POWER PRODUCTS IS PROHIBITED.

ANDERSON POWER PRODUCTS RESERVES THE RIGHT TO ALTER PRODUCT TYPES, THEIR TECHNICAL DATA, DIMENSION, STYLE AND ACCESSORIES WITHOUT PRIOR NOTIFICATION.

DATE	**
BY:	**
DESCRIPTION OF CHANGES	**
REV.	**

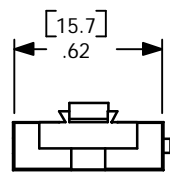
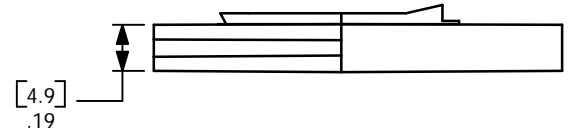
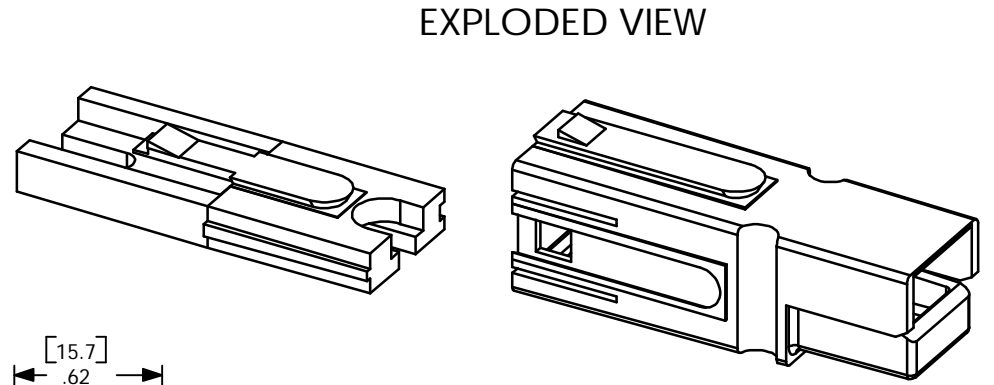
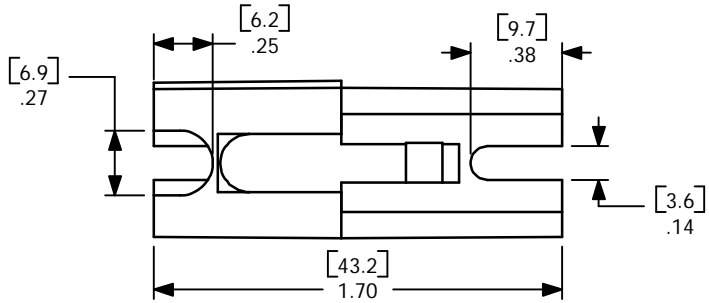

TWO ADAPTERS MOUNTED SIDE BY SIDE

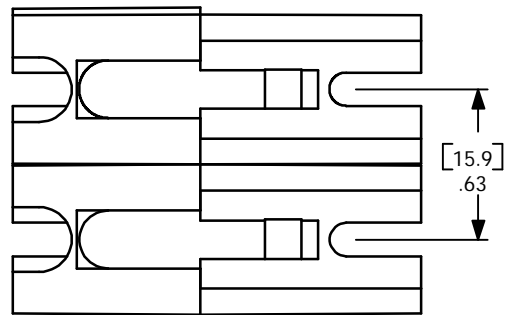

NOTES:

1. AVAILABLE IN BLUE ONLY
2. USE SCREW(S) TO MOUNT (NOT INCLUDED)
3. TO BE USED WITH THE PP75 LOCKING SERIES ONLY

ITEM NO.	PART OR IDENTIFYING NO.	NOMENCLATURE OR DESCRIPTION	MATERIAL SPECIFICATION	QTY REQD
COPYRIGHT 2001 ANDERSON POWER PRODUCTS. ALL RIGHTS RESERVED. UNAUTHORIZED REPRODUCTION HEREBY PROHIBITED.				
DIMENSIONS ARE IN INCHES DIMENSIONS IN PARENTHESES [] ARE IN MILLIMETERS		CAD GENERATED DRAWING, DO NOT MANUALLY UPDATE		ANDERSON POWER PRODUCTS
TOLERANCES ARE: 2PL- ±.02 [±.5]		APPROVALS	DATE	
		DRAWN	CMS	5/11/01
		CHECKED	DJD	5/17/01
		RESP ENG	UFN	5/18/01
		MFG ENG	CHB	5/18/01
		DUAL ENG	RPO	5/17/01
NEXT ASSY	USED ON	FINISH AS MOLDED		SIZE A
APPLICATION		DO NOT SCALE DRAWING		SPECIFICATION: 114320S1
		SCALE NONE		REV. 0
		CADFILES/01442		SHEET 1 OF 1