

The Anderson Power Products Power Clip is designed as a low cost interconnection between two perpendicular power bus bars. The product's high performance contact offers low voltage drop and superior amperage carrying capability. There is no mating connector to the Power Clip as it accepts a solid .125 inches or 3mm thick nickel or gold plated rectangular bus bar tab.

The product is often used in "N+1" rectifier, power supply and switching power supply applications. The Power Clip's design enables the connector to be blind mated in the deepest racks.



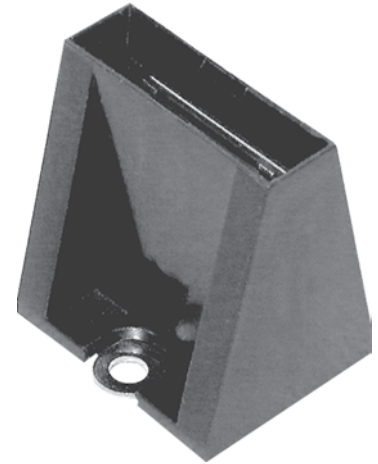

The Power Clip is recognized to UL1977 and CSA standard C22.2 and is rated for up to 300 amps continuous service. The product is also UL approved for hot plug current interruption of 100A at 48V and 200A at 42V using a gold plated bus bar tab.

## FEATURES

- High 300A Current Rating**  
*Small size provides dense power packaging*
- Mates with .125 inches or 3mm Flat Bus Bar Blade**  
*Simplifies construction and lowers cost*
- Blind Mating Design**  
*Allows greater vertical chassis manufacturing tolerances*
- Hot Pluggable Contact**  
*Supports hot swapping on 48 volt DC bus*
- UL, TUV and CUR Recognized**  
*Product safety and electrical performance has been verified to the highest standards*



## PRODUCT SPECIFICATIONS

Electrical	Mechanical	Materials
Current Rating (Amperes) (1)	Insertion Force (lbs)	Housing
UL	(N)	PBT UL94 V-0
CSA (30°C Rise)	Extraction Force (lbs)	Contact Band
UL / CSA Voltage Rating (AC/DC)	(N)	Beryllium copper alloy
Operating Temperature Range	Mating	Plating gold
(C°)	a. No Load ( mating cycles)	0.4 to 0.6 microns over 2 to
(F°)	b. Under Load (2)	5 microns nickel
Average Contact Resistance	(Hot Plug 250 mating cycles @ 48V)	Contact Holder
(micro-ohm)	(Hot Plug 250 mating cycles @ 42V)	Copper alloy
		Plating gold
		0.1 to 0.2 microns
		(1) Ratings using nickel plated tab
		(2) Ratings using gold plated, solid copper tab
		   

## ORDERING INFORMATION

### Complete Connector

Part Number	Description
PCL01	Power Clip Connector

## TEMPERATURE CHART

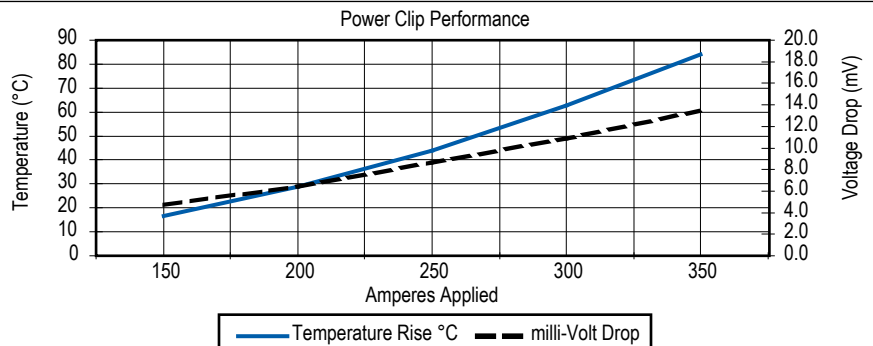

The graph shows the Power Clip electrical performance in terms of temperature rise and voltage drop at currents from 150A to 350A. The set up for the test consisted of the following:

- Six Power Clips were mounted on a bus bar that was 0.25 x 1.75 x 6.0 inches in diameter.
- Six test samples were connected in series using 1/0 AWG wire attached to a 1" long and .125" thick nickel plated mating blades.

## DIMENSIONS

**Side View**

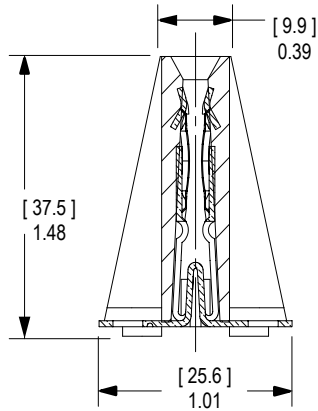

**Top View**

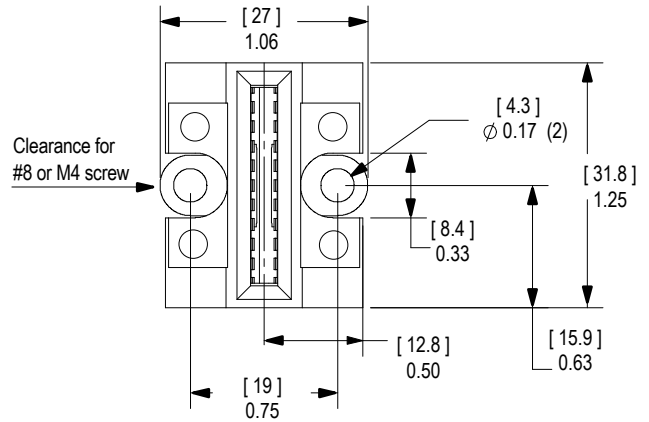

**Mating Blade - Required Dimensions**

