

THE INFORMATION CONTAINED IN THIS DRAWING IS THE SOLE PROPERTY OF ANDERSON POWER PRODUCTS. ANY REPRODUCTION IN PART OR WHOLE WITHOUT THE WRITTEN PERMISSION OF ANDERSON POWER PRODUCTS IS PROHIBITED.

Copyright 2006

ANDERSON POWER PRODUCTS RESERVES THE RIGHT TO ALTER PRODUCT TYPES, THEIR TECHNICAL DATA, DIMENSION, STYLE AND ACCESSORIES WITHOUT PRIOR NOTIFICATION.

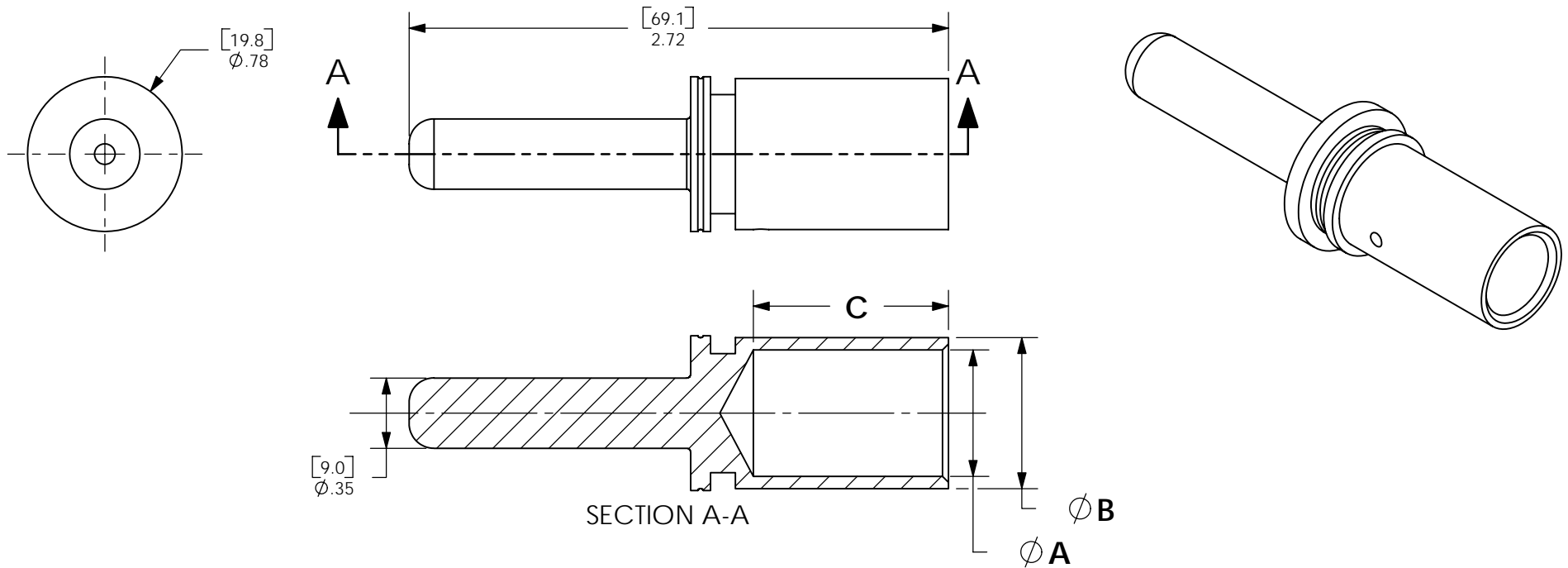

| PART NO  | WIRE SIZE    | A   |      | B   |      | C   |      |
|----------|--------------|-----|------|-----|------|-----|------|
|          |              | IN  | mm   | IN  | mm   | IN  | mm   |
| PMHPBP01 | 4/0          | .64 | 16.2 | .76 | 19.3 | .98 | 25.0 |
| PMHPBP02 | 95mm sq      | .59 | 15.0 | .78 | 19.8 | .98 | 25.0 |
| PMHPBP03 | 2/0-70mm sq  | .51 | 13.0 | .67 | 17.0 | .79 | 20.0 |
| PMHPBP04 | 1/0- 50mm sq | .44 | 11.3 | .57 | 14.5 | .79 | 20.0 |

NOTES:

- CONTACTS TO BE USED IN POWERMOD HP B SERIES HOUSINGS ONLY
- CONTACTS MUST BE CRIMPED ONTO WIRE BEFORE ASSEMBLY INTO HOUSINGS
- REFER TO DATA SHEET FOR CRIMP TOOLING

|                          |               |   |            |                             |
|--------------------------|---------------|---|------------|-----------------------------|
| DIMENSIONS ARE IN:       | INCH[MM]      | APPROVALS   |            | <br>ANDERSON POWER PRODUCTS |
| UNLESS OTHERWISE STATED  |               | DRAWN   | CMS 6/2/06 |                             |
| TOLERANCES:              |               | CHECKED   | DJD 6/8/06 |                             |
| DECIMALS (INCH)          | DECIMALS (MM) | ANGLES  | MFG APP    |                             |
| .XX ± .02                | .X ± .5       | ±2°   | CHB 6/7/06 |                             |
| SURFACE FINISH:          |               | QC APP  | UFN 6/5/06 | SIZE<br>A/A4                |
| MACHINED 128 [3.2] ✓     |               | ENG APP   | DAM 6/2/06 |                             |
| MOLDED 64 [1.6] ✓        |               | MATERIAL: COPPER ALLOY                                      |            | DWG NO.                     |
| FINISH: SILVER PLATE     |               | CAD GENERATED DRAWING. DO NOT MANUALLY UPDATE. DO NOT SCALE |            | 114663S1                    |
| <br>3rd ANGLE PROJECTION |               | SCALE   |            | REV.                        |
| NONE                     |               | CADFILE   |            | 0                           |
| SHEET                    |               | SHEET   |            | 1 OF 1                      |
| NONE                     |               | 02539   |            |                             |

| REV. | DESCRIPTION OF CHANGES | APPROVED | DATE  |
|------|------------------------|----------|-------|
| *    | *****                  | ***      | ***** |