

THE INFORMATION CONTAINED IN THIS DRAWING IS THE SOLE PROPERTY OF ANDERSON POWER PRODUCTS. ANY REPRODUCTION IN PART OR WHOLE WITHOUT THE WRITTEN PERMISSION OF ANDERSON POWER PRODUCTS IS PROHIBITED.

Copyright 2008

ANDERSON POWER PRODUCTS RESERVES THE RIGHT TO ALTER PRODUCT TYPES, THEIR TECHNICAL DATA, DIMENSION, STYLE AND ACCESSORIES WITHOUT PRIOR NOTIFICATION.

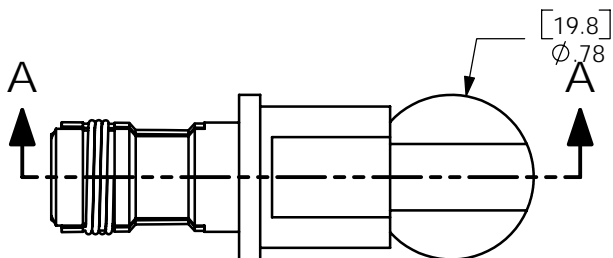

FULLY ASSEMBLED CONTACT

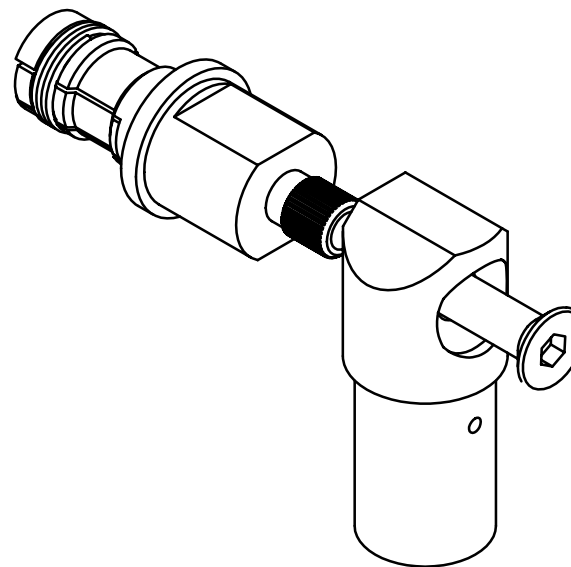

EXPLODED VIEW

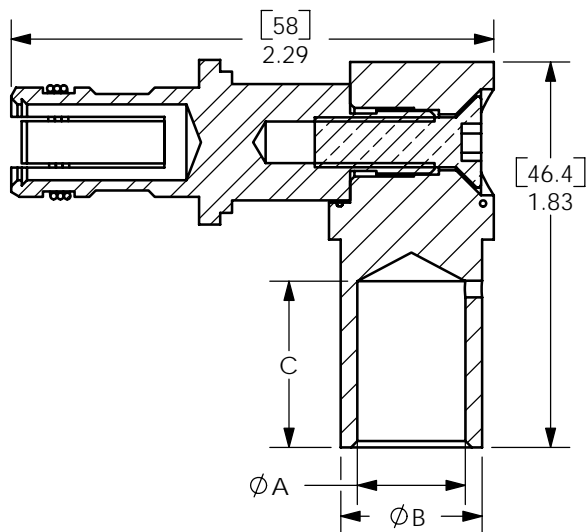

SECTION A-A

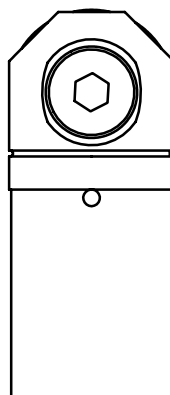

PART NO	WIRE SIZE	A		B		C	
		IN	mm	IN	mm	IN	mm
PMHPBS06	4/0 AWG	.64	16.2	.76	19.3	.98	25.0
PMHPBS07	95mm sq	.59	15.0	.78	19.8	.98	25.0
PMHPBS08	2/0 AWG/70mm sq	.51	13.0	.67	17.0	.79	20.0
PMHPBS09	1/0 AWG/50mm sq	.44	11.3	.57	14.5	.79	20.0

NOTES:

- MATERIALS:
SOCKET BODY AND CRIMP BARREL- COPPER ALLOY, SILVER PLATE
SPRING- STAINLESS STEEL
FH SCREW- STAINLESS STEEL
- RIGHT ANGLE CONTACTS ARE PROVIDED AS A 3 PIECE KIT: SOCKET BODY WITH SPRING, CRIMP BARREL, AND FH SCREW. CUSTOMER MUST MUST ATTACH SOCKET BODY TO CRIMP BARREL WITH PROVIDED SCREW AFTER CRIMPING WIRE. (REFER TO ASSEMBLY INSTRUCTIONS)
- CONTACTS TO BE USED IN POWERMOD HPB SERIES R/A HOUSINGS ONLY

DIMENSIONS ARE IN:		APPROVALS		ANDERSON POWER PRODUCTS		
INCH[MM]		DRAWN	CMS 6/4/08	TITLE PMHPB SERIES RIGHT ANGLE FEMALE CONTACT KITS		
UNLESS OTHERWISE STATED		CHECKED	DJD 6/4/08			
TOLERANCES:		MFG APP	CHB 6/5/08			
DECIMALS (INCH) DECIMALS (MM) ANGLES		QC APP	UFN 6/6/08			
.XX ± .02 .X ± .5 ± 2°		ENG APP	DAM 6/9/08	SIZE	DWG NO.	REV.
SURFACE FINISH:				A/A4	114783S1	0
MACHINED 128 [3.2] ✓				SCALE	CADFILE	SHEET
MOLDED 64 [1.6] ✓				NONE	02790	1 OF 1
MATERIAL: SEE NOTES		CAD GENERATED DRAWING. DO NOT MANUALLY UPDATE. DO NOT SCALE				
FINISH: SEE NOTES						

REV.	DESCRIPTION OF CHANGES	APPROVED	DATE
1.			