

THE INFORMATION CONTAINED IN THIS DRAWING IS THE SOLE PROPERTY OF ANDERSON POWER PRODUCTS. ANY REPRODUCTION IN PART OR WHOLE WITHOUT THE WRITTEN PERMISSION OF ANDERSON POWER PRODUCTS IS PROHIBITED.

Copyright 2017

ANDERSON POWER PRODUCTS RESERVES THE RIGHT TO ALTER PRODUCT TYPES, THEIR TECHNICAL DATA, DIMENSION, STYLE AND ACCESSORIES WITHOUT PRIOR NOTIFICATION.

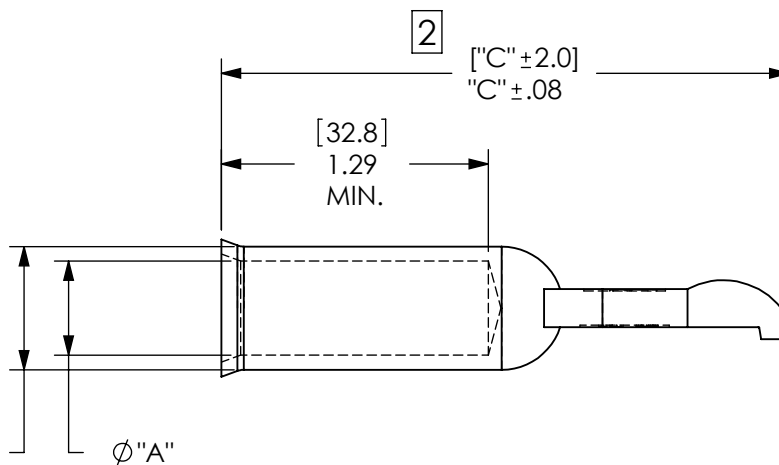
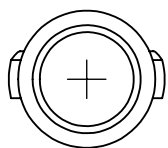
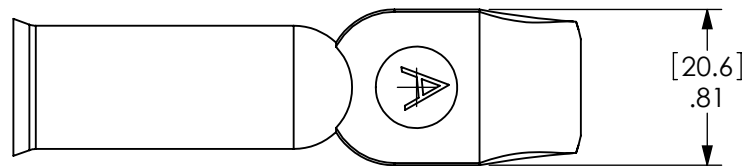
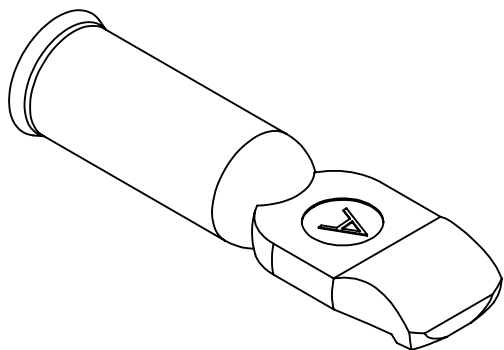

3

2

3

NOTE:
CONTACTS SOLD IN PAIRS

CAT. NO	WIRE SIZE	"A"		"B"		"C"	
		INCH	MM	INCH	MM	INCH	MM
910	300 MCM	.75	19.1	.87	22.1	3.04	77.2
908	#4/0 AWG	.64	16.3	.75	19.1	3.03	77.0
916	#3/0 AWG	.58	14.7	.70	17.8	3.00	76.2
907	#2/0 AWG	.49	12.4	.64	16.3	2.96	75.2
917	#1/0 AWG	.44	11.1	.51	13.0	2.91	73.8

DIMENSIONS ARE IN:	INCH [MM]	<i>APPROVALS</i>			ANDERSON POWER PRODUCTS	
UNLESS OTHERWISE STATED		DRAWN	7/9/2008		TITLE	
TOLERANCES:		CMS	7/9/2008	SB350 CONTACTS		
DECIMALS (INCH)	DECIMALS (MM)	CHECKED	7/9/2008			
.XX ± .015	.X ± .38	MFG APPRV	7/12/2008			
.XXX ± .005	.XX ± .13	CHB	7/12/2008			
SURFACE FINISH:		QC APPRV	7/13/2008			
MACHINED	128µin [3.2µ]	DJM	7/13/2008	SIZE	DWG NO.	
MOLDED	64µin [1.6µ]	ENG APPRV	7/12/2008	A	114159S1	
MATERIAL:		CHB		SCALE	CADFILE	
COPPER ALLOY				1:1	01070	
FINISH:				SHEET	SHEET	
SILVER PLATE				1 OF 1	1 OF 1	
		-CAD GENERATED DRAWING- DO NOT MANUALLY UPDATE DO NOT SCALE				