

THE INFORMATION CONTAINED IN THIS DRAWING IS THE SOLE PROPERTY OF ANDERSON POWER PRODUCTS. ANY REPRODUCTION IN PART OR WHOLE WITHOUT THE WRITTEN PERMISSION OF ANDERSON POWER PRODUCTS IS PROHIBITED.

REV.	DESCRIPTION OF CHANGES	BY:	DATE
1	ECRN 13717	CMS	7/9/04
2	ECRN-14849 CLAMP THICKNESS DIM	TWE	3/8/11

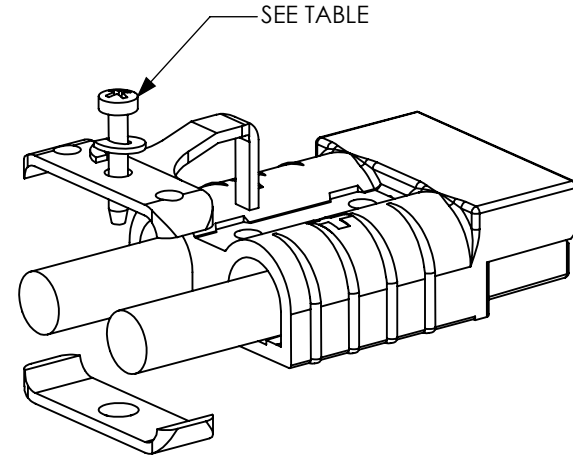
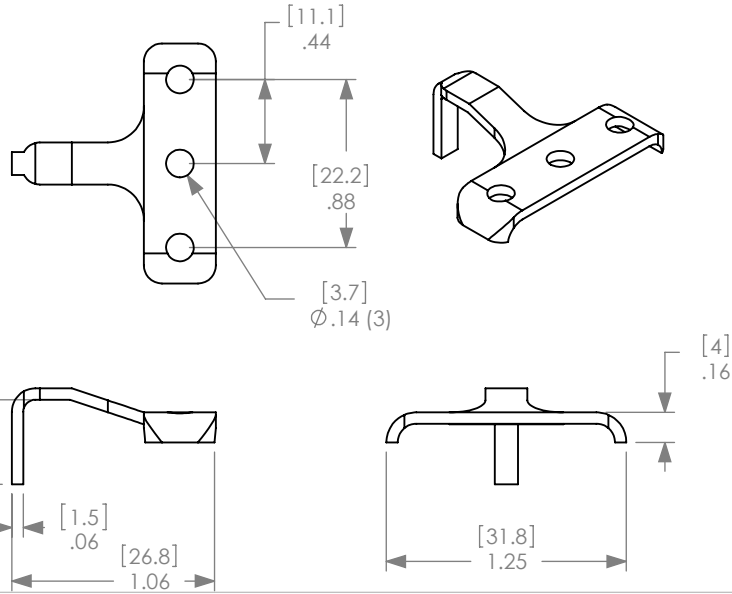

MOUNTING OF CABLE CLAMP

CAT. NO.	SCREW LENGTH	
	IN	MM
990	3/4"	19
990G2	5/8"	15.9

NOTES:

1. MATERIAL: COLD ROLLED STEEL, ZINC YELLOW FINISH
2. HARWARE KIT INCLUDES ONE SELF-TAPPING SCREW AND ONE LOCK WASHER
3. USE WITH TWO #6-8 OR #10-12 SINGLE CONDUCTOR CABLES

ITEM NO.	PART OR IDENTIFYING NO.	NOMENCLATURE OR DESCRIPTION	MATERIAL SPECIFICATION	QTY REQD
----------	-------------------------	-----------------------------	------------------------	----------

COPYRIGHT 2000 ANDERSON POWER PRODUCTS. ALL RIGHTS RESERVED. UNAUTHORIZED REPRODUCTION HEREBY PROHIBITED.

DIMENSIONS ARE IN INCHES DIMENSIONS IN PARENTHESES [] ARE IN MILLIMETERS		CAD GENERATED DRAWING, DO NOT MANUALLY UPDATE		ANDERSON POWER PRODUCTS	
TOLERANCES ARE: 2PL- ±.02 [±.5]		APPROVALS			
MATERIALS: SEE NOTES		DRAWN		CMS 1/25/00	
FINISH SEE NOTES		CHECKED		DJD 1/28/00	
DO NOT SCALE DRAWING		RESP ENG		UFN 2/7/00	
NEXT ASSY		MFG ENG		CHB 2/8/00	
USED ON		QUAL ENG		RPO 2/8/00	
APPLICATION		SCALE		NONE	
		SPECIFICATION:		114224S1	
		CADFILES/01175		SHEET 1 OF 1	

NEXT ASSY	USED ON
APPLICATION	

