

THE INFORMATION CONTAINED IN THIS DRAWING IS THE SOLE PROPERTY OF ANDERSON POWER PRODUCTS. ANY REPRODUCTION IN PART OR WHOLE WITHOUT THE WRITTEN PERMISSION OF ANDERSON POWER PRODUCTS IS PROHIBITED.

Copyright 1999

ANDERSON POWER PRODUCTS RESERVES THE RIGHT TO ALTER PRODUCT TYPES, THEIR TECHNICAL DATA, DIMENSION, STYLE AND ACCESSORIES WITHOUT PRIOR NOTIFICATION.

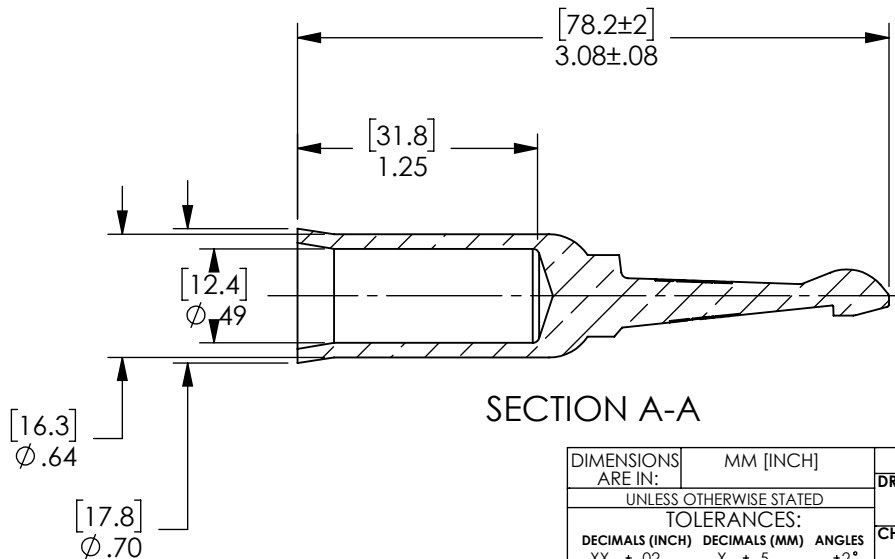
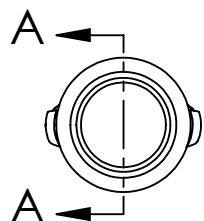
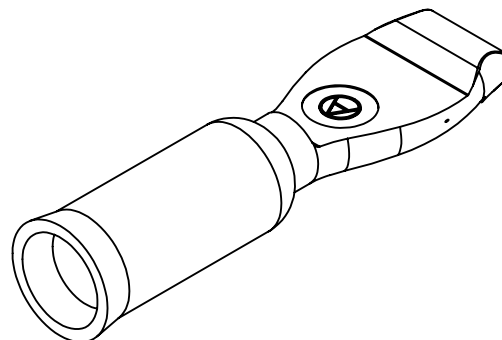
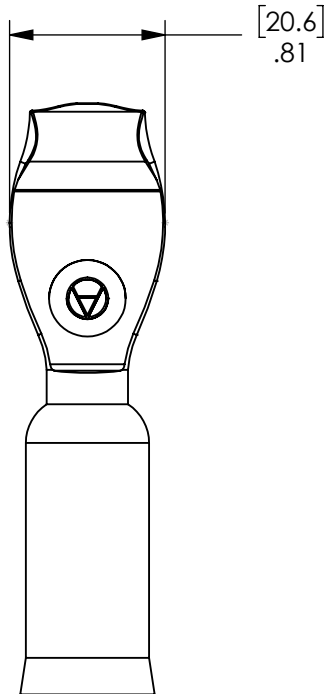

SECTION A-A

REV.	DESCRIPTION	APPRV	DATE
3	ECN 2019-0149 - UPDATED DIMENSIONS	CPD	11/12/2019
2	ECRN-15906	CPD	2/19/16
1	ECRN-15089	TWE	3/20/12
REVISIONS			

DIMENSIONS ARE IN: MM [INCH]		APPROVALS		<p>ANDERSON POWER PRODUCTS</p> <p>TITLE</p> <p>CATALOG NUMBER 6354 SBE 320/SBX 350 CONTACT FOR 2/0 WIRE</p>
UNLESS OTHERWISE STATED		DRAWN	CMS 7/26/1999	
TOLERANCES:		CHECKED	AC 7/27/1999	
DECIMALS (INCH) DECIMALS (MM) ANGLES .XX ± .02 .X ± .5 ± 2°		MFG APPRV	UFN 7/27/1999	
SURFACE FINISH:		QC APPRV	CHB 7/27/1999	
MACHINED 3.2µ [128µin] ✓		ENG APPRV	DJM 7/27/1999	
MOLDED 1.6µ [64µin] ✓				
MATERIAL: COPPER		SIZE	A	
FINISH: SILVER PLATE		DWG NO.	114163S1	
		REV.	3	
-CAD GENERATED DRAWING- DO NOT MANUALLY UPDATE DO NOT SCALE		SCALE	NONE	
		CADFILE	01078	
		SHEET	1 OF 1	