

THE INFORMATION CONTAINED IN THIS DRAWING IS THE SOLE PROPERTY OF ANDERSON POWER PRODUCTS. ANY REPRODUCTION IN PART OR WHOLE WITHOUT THE WRITTEN PERMISSION OF ANDERSON POWER PRODUCTS IS PROHIBITED.

Copyright 2010

ANDERSON POWER PRODUCTS RESERVES THE RIGHT TO ALTER PRODUCT TYPES, THEIR TECHNICAL DATA, DIMENSION, STYLE AND ACCESSORIES WITHOUT PRIOR NOTIFICATION.

CABLE CLAMP MAIN BODY

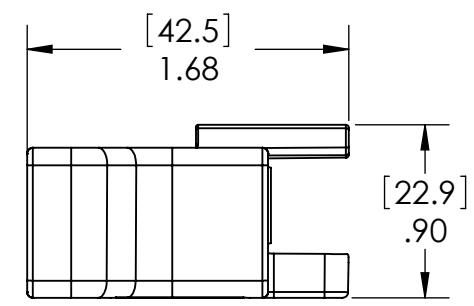
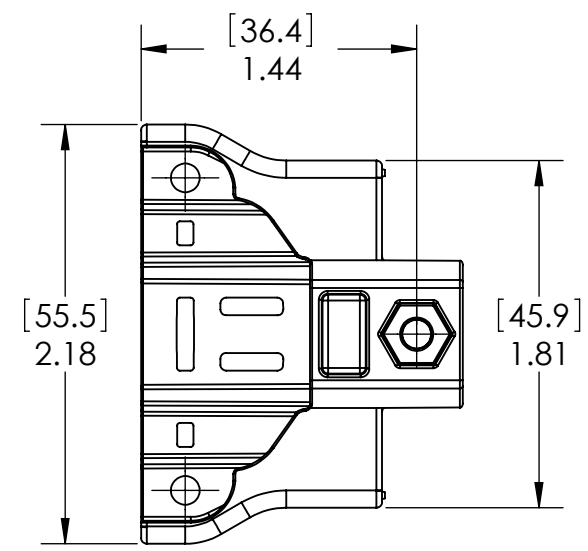

CABLE CLAMP

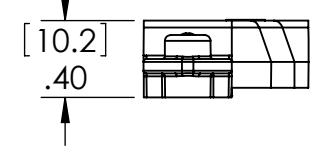
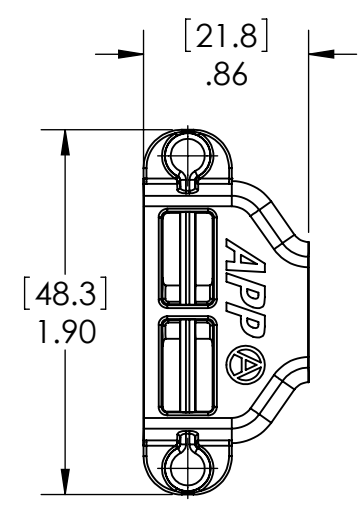

PART ID

MATED PAIR WITH CLAMP

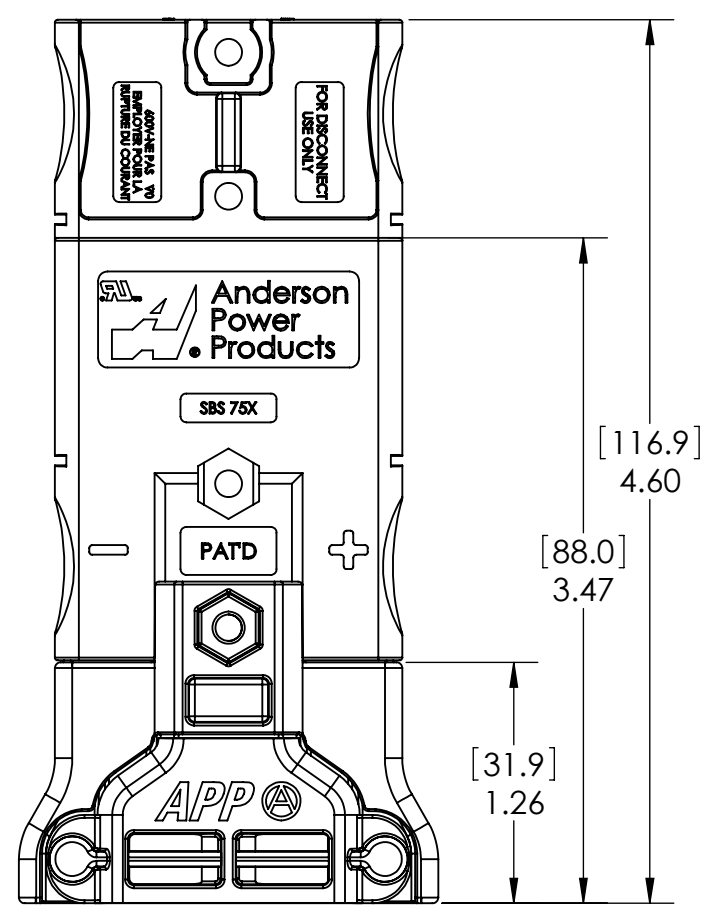

CLAMP

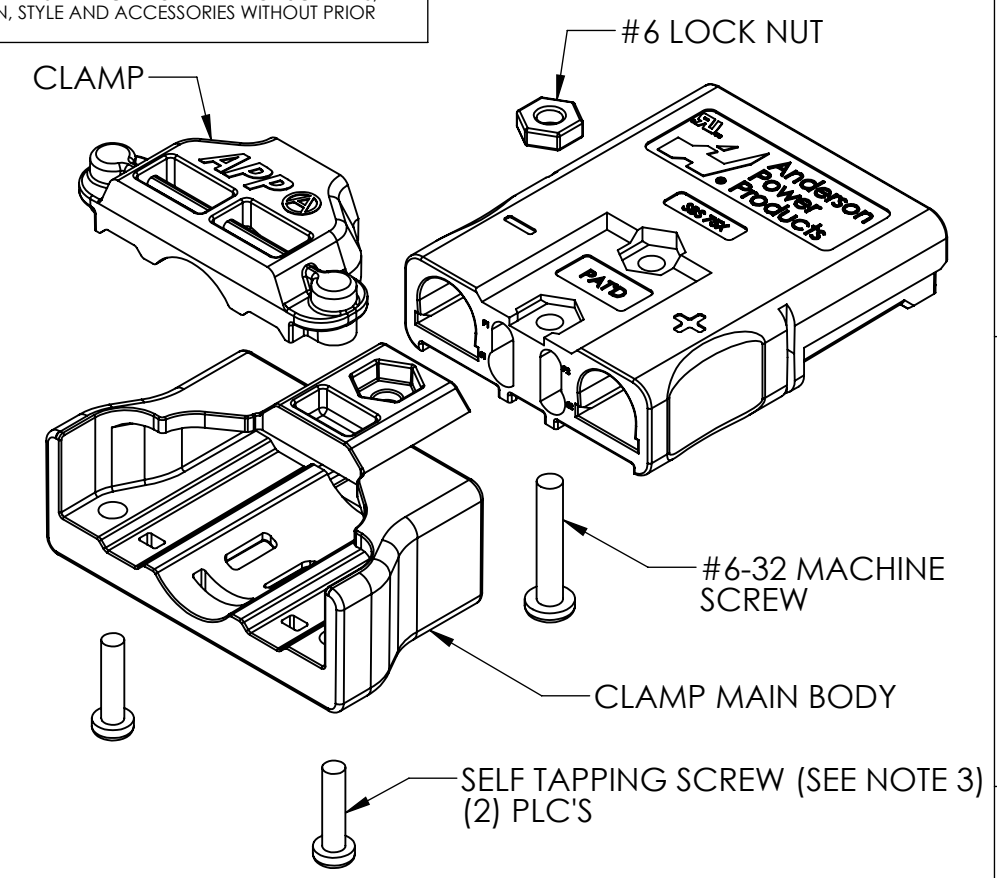

- NOTES**
- CABLE CLAMP COLOR: BLACK
CABLE CLAMP MAIN BODY COLOR: BLACK
 - CABLE CLAMP SHOWN WITH SBS75X CONNECTOR
 - EACH CABLE CLAMP KIT INCLUDES TWO SETS OF SELF-TAPPINGSCREWS IN THE FOLLOWING SIZES: #6 X 3/8[9.5] AND #6 X 1/2[12.7]. SEE ASSEMBLY INSTRUCTIONS 1S6417 FOR USE OF EACH SIZE.
 - A WIRE TIE (NOT SHOWN) IS INCLUDED WITH EACH CABLE CLAMP KIT. SEE ASSEMBLY INSTRUCTIONS 1S6417 FOR PROPER USE.

P/N	PART ID	CABLE SIZE	
		DISCRETE WIRE	BUNDLED CABLE
PSBS75XCLP1	"P1"	14 AWG TO 6 AWG POWER CABLES	[ϕ 9.9 - ϕ 15.2] ϕ 0.39 - ϕ 0.60
PSBS75XCLP2	"P2"		[ϕ 8.6 - ϕ 14.0] ϕ 0.34 - ϕ 0.55

REV.	DESCRIPTION	APPRV	DATE
3	ECRN 14883	NTS	4/14/2011
2	ECRN 14803	NTS	12/20/2010
1	ECRN 14730	NTS	10/20/2010

REVISIONS

DIMENSIONS ARE IN:			APPROVALS	
INCH [MM]			DRAWN	NTS 6/15/2010
UNLESS OTHERWISE STATED			CHECKED	DJD 6/16/2010
TOLERANCES:			MFG APPRV	CHB 6/15/2010
DECIMALS (INCH)	DECIMALS (MM)	ANGLES	QC APPRV	UFN 6/15/2010
.XX ± .02	.X ± .5	± 2°	ENG APPRV	BD 6/15/2010
SURFACE FINISH:			MATERIAL: PBT + PC BLEND	
MACHINED 64 [1.6]			FINISH: SPI #2	
MOLDED 32 [0.8]			-CAD GENERATED DRAWING- DO NOT MANUALLY UPDATE DO NOT SCALE	

ANDERSON POWER PRODUCTS

TITLE
SBS75X CABLE CLAMP
P/N: PSBS75XCLPX

SIZE B **DWG NO.** B02086S1 **REV.** 3

SCALE NONE **CADFILE** 03044 **SHEET** 1 OF 1

E
D
C
B
A

E
D
C
B
A

8 7 6 5 4 3 2 1