

5 Position Mini PL SPEC Pak® Inline Receptacle (male) Assembly Instructions

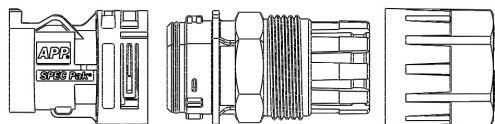

- Tools & supplies you will need:**
- Wire strippers
 - Wire lubricant
 - Crimp tool(s)
 - Insertion tool
 - Extraction tool
 - Wrench

Step 1 Wire Protection

- a. Strip approximately 0.75 inches (19 mm) from the outer cable jacket, if applicable.
- b. Lubricate wires (or jacketed cable) using Isopropyl alcohol. **WARNING:** Dry thoroughly before energizing the circuit. Follow all cautions on the lubricant container.
- c. Slide approximately 1.6" (40 mm) of wires through wire protection nut and then through the sealing grommet side of the sealing grommet assembly. (See figure 1)

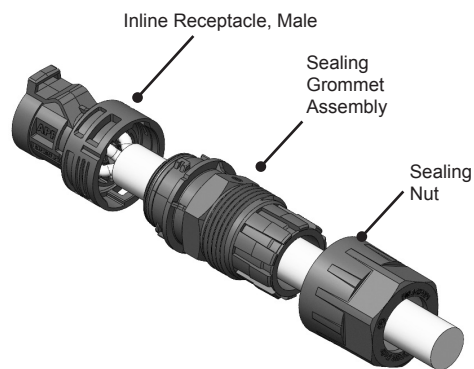

Step 2 Prepare Wires

- a. Strip individual wires taking care not to damage the copper conductor. (See Table 1)

Table 1 (See figure 2)

APP Contact Part Number	X Inches	X (mm)	Instruction Sheet
PM16P2024S30	Wire Insulation OD < crimp barrel ID x = 0.18" (4.5mm)	----	1S6420
PM16P1620S30			
PM16P1416S30	Wire Insulation OD > crimp barrel ID x = 0.24" (6mm)	----	
PM16P12S30			

Figure 1

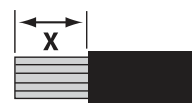

Figure 2

Step 3 Crimp Contacts

- a. Crimp contacts per crimp tool instructions. (See Table 2)
WARNING: APP tooling is required for UL and CSA compliance. Use of unapproved tooling will void the connector warranty.

Table 2

APP Contact Part Number	Wire Size	Hand Tool Part Number	Instruction Sheet	Please inquire for additional tooling options:
PM16P2024S30	24 – 20 AWG 0.25 – 0.50 mm ²	PM1000G1	1S6497	Pneumatic
PM16P1620S30	20 – 16 AWG 0.50 – 1.30 mm ²			
PM16P1416S30	16 – 14 AWG 1.30 – 2.10 mm ²			
PM16P12S30	12 AWG 3.30 mm ²			

5 Position Mini PL
SPEC Pak® Inline Receptacle (male)
Page 2

Step 4 Contact Installation

- a. Insert the contact from the rear side of the connector, using insertion tool (part number PM1002G1). (See figure 3)
 - i. **NOTE:** A tactile snap will be felt when contacts are properly inserted. Apply a slight tug on the wire to confirm that the contact is properly inserted. If using discrete wires, the wires will spin freely when properly inserted in the housing.
 - ii. **NOTE:** If necessary, contacts can be extracted by using extraction tool part number PM1003G1. (See figure 4)
 1. Slide tool over the contact until the tool bottoms on the housing.
 2. Push the button on the top of the tool with your thumb while gently pulling on the wires from the back of the connector.
 3. Contact will be released.
- b. Repeat Step 4a as necessary.



Figure 3

Step 5 Final Assembly

- a. Insert the sealing grommet assembly in the back of the connector and twist to lock. (See figure 5)
- b. Gently pull on the wires to remove excess slack in the wires.
- c. Hand tighten sealing nut.
- d. Wrench (24mm wrench or strap wrench) tighten sealing nut 1/4 – 1/2 turn more.



Figure 4

Step 6 Assembly is complete. (See figure 6)

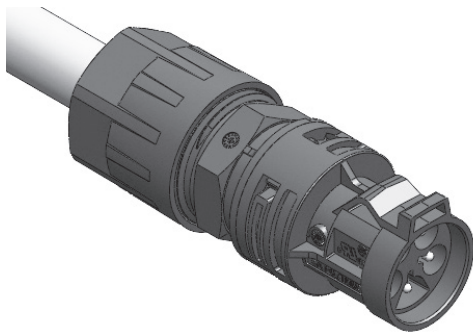

Figure 6

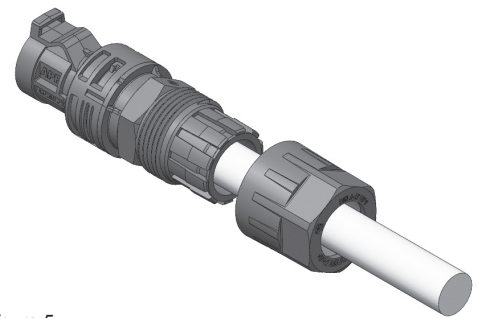

Figure 5