

8 7 6 5 4 3 2 1

THE INFORMATION CONTAINED IN THIS DRAWING IS THE SOLE PROPERTY OF ANDERSON POWER PRODUCTS. ANY REPRODUCTION IN PART OR WHOLE WITHOUT THE WRITTEN PERMISSION OF ANDERSON POWER PRODUCTS IS PROHIBITED.

Copyright 2008

ANDERSON POWER PRODUCTS RESERVES THE RIGHT TO ALTER PRODUCT TYPES, THEIR TECHNICAL DATA, DIMENSION, STYLE AND ACCESSORIES WITHOUT PRIOR NOTIFICATION.

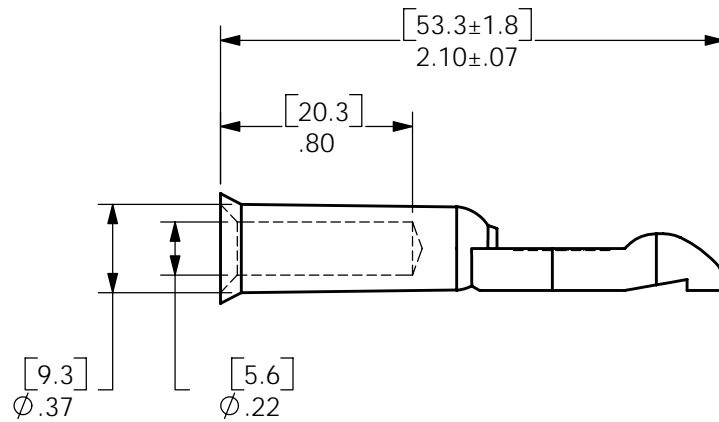
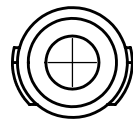
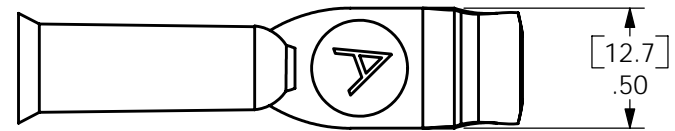
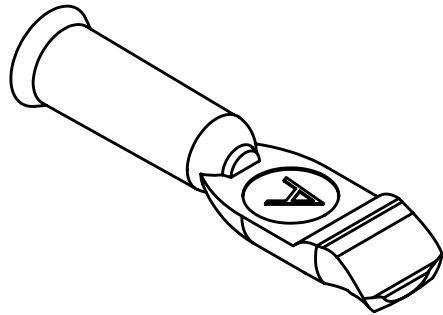

CAT. NO 1348

DIMENSIONS ARE IN: INCH[MM]		APPROVALS		 ANDERSON POWER PRODUCTS
UNLESS OTHERWISE STATED		DRAWN	CMS 7/2/99	
TOLERANCES:		CHECKED	DJD 7/6/99	
DECIMALS (INCH)	DECIMALS (MM)	ANGLES	MFG APP	
.XX ±.02	.X ±.5	±2°	CHB 7/7/99	
SURFACE FINISH:		QC APP	DJM 7/7/99	SIZE A/A4
MACHINED	128 [3.2] ✓	ENG APP	UFN 7/19/99	
MOLDED	64 [1.6] ✓	FINISH: SILVER PLATE		REV. 1
MATERIAL: COPPER ALLOY		CAD GENERATED DRAWING. DO NOT MANUALLY UPDATE. DO NOT SCALE		SCALE NONE
1 ECRN 14358 - REVISE, REDRAW AMS 12/17/08		3rd ANGLE PROJECTION		CADFILE 01069
REV.	DESCRIPTION OF CHANGES	APPROVED	DATE	SHEET 1 OF 1

8 7 6 5 4 3 2 1