

THE INFORMATION CONTAINED IN THIS DRAWING IS THE SOLE PROPERTY OF ANDERSON POWER PRODUCTS. ANY REPRODUCTION IN PART OR WHOLE WITHOUT THE WRITTEN PERMISSION OF ANDERSON POWER PRODUCTS IS PROHIBITED.

Copyright 2012

ANDERSON POWER PRODUCTS RESERVES THE RIGHT TO ALTER PRODUCT TYPES, THEIR TECHNICAL DATA, DIMENSION, STYLE AND ACCESSORIES WITHOUT PRIOR NOTIFICATION.

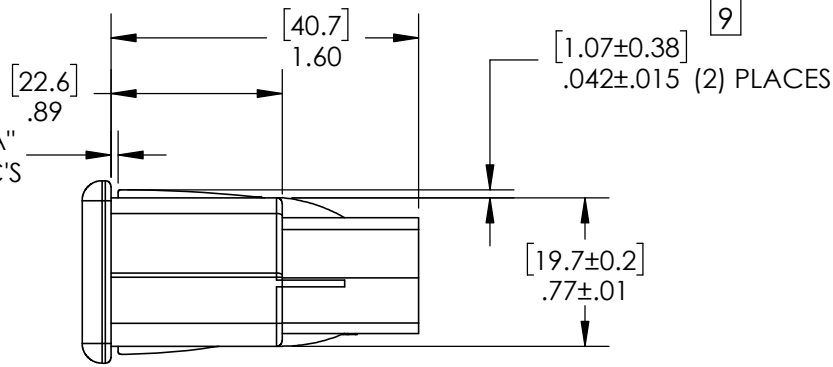
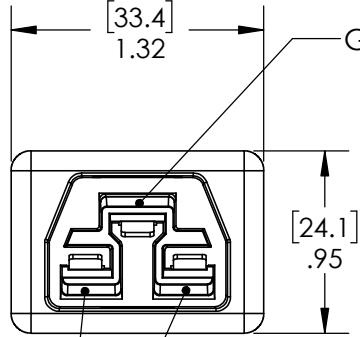
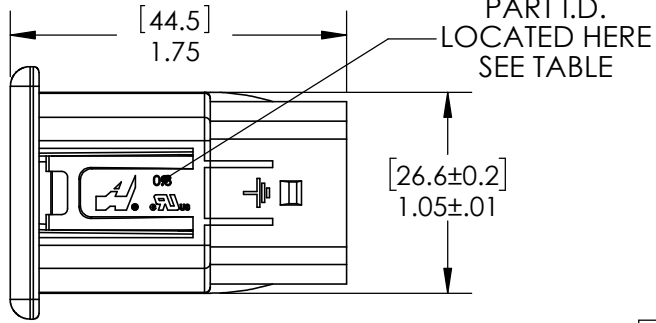
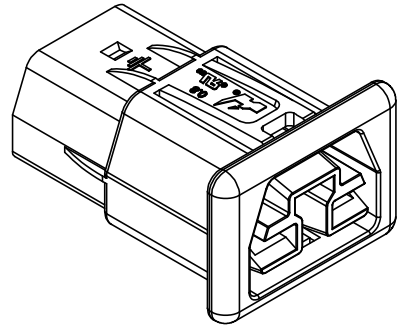

PART I.D. LOCATED HERE SEE TABLE

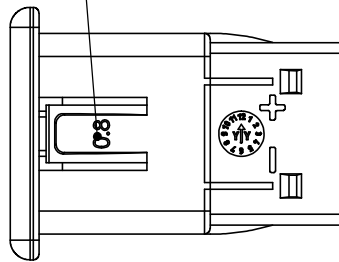

BLACK HOUSING CAT. NO.	GRAY HOUSING CAT. NO.	PANEL THICKNESS		DIM "A" ^{+0.006[0.15]} _{-.004[0.10]}		PART ID
		INCH	MM	INCH	MM	
2002G1	2002G1-GRY	.031	0.80	.036	0.91	"0.8"
2002G2	2002G2-GRY	.047	1.20	.056	1.42	"1.2"
2002G3	2002G3-GRY	.039	1.00	.044	1.13	"1.0"
2002G4	2002G4-GRY	.063	1.60	.072	1.82	"1.6"
2002G5	2002G5-GRY	.079	2.00	.088	2.24	"2.0"
2002G6	2002G6-GRY	.098	2.50	.107	2.72	"2.5"

- NOTES:
- FOR USE WITH IEC320 C14 PANEL CUT-OUTS.
 - HOUSING MATERIAL: POLYCARBONATE, COLOR PER CHART.
 - SPRING MATERIAL: STAINLESS STEEL

REV.	DESCRIPTION	APPRV	DATE
9	ECN 2016-0076 - ADDED .42 DIMENSION	CPD	12/7/2016
7	ECRN 15422	CLY	6/18/2013
6	ECRN 15384	CLY	4/24/2013
5	ECRN 15280	CLY	12/10/2012
4	ECRN 15074	CLY	2/27/2012
3	ECRN 14928	NTS	6/24/11

REVISIONS

DIMENSIONS ARE IN: INCH [MM]

UNLESS OTHERWISE STATED TOLERANCES:

DECIMALS (INCH)	DECIMALS (MM)	ANGLES
.XX ±.02	.X ±.5	±2°

SURFACE FINISH:

MACHINED	128µin [3.2µ]	✓
MOLDED	64µin [1.6µ]	✓

MATERIAL: SEE NOTES

FINISH: N/A

3rd ANGLE PROJECTION

APPROVALS

DRAWN	AMS	4/27/2009
CHECKED	DJD	4/27/2009
MFG APPRV	CHB	4/27/2009
QC APPRV	UFN	4/27/2009
ENG APPRV	DAM	4/27/2009

ANDERSON POWER PRODUCTS

TITLE

RECEPTACLE HOUSING FOR SAF-D-GRID® 2002 SERIES

SIZE	DWG NO.	REV.
A	114868S1	9
SCALE	CADFILE	SHEET
NONE	02905	1 OF 1