

THE INFORMATION CONTAINED IN THIS DRAWING IS THE SOLE PROPERTY OF ANDERSON POWER PRODUCTS. ANY REPRODUCTION IN PART OR WHOLE WITHOUT THE WRITTEN PERMISSION OF ANDERSON POWER PRODUCTS IS PROHIBITED.

**Copyright 2012**

ANDERSON POWER PRODUCTS RESERVES THE RIGHT TO ALTER PRODUCT TYPES, THEIR TECHNICAL DATA, DIMENSION, STYLE AND ACCESSORIES WITHOUT PRIOR NOTIFICATION.

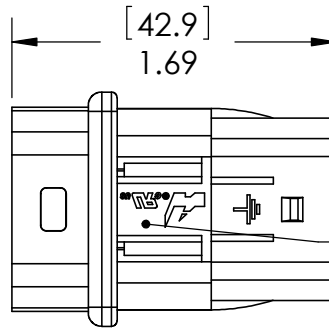
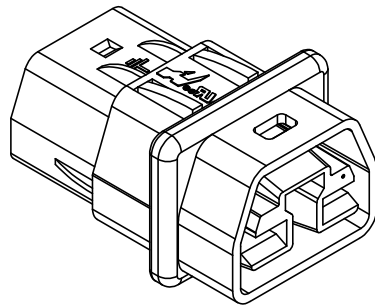

PART ID LOCATED HERE

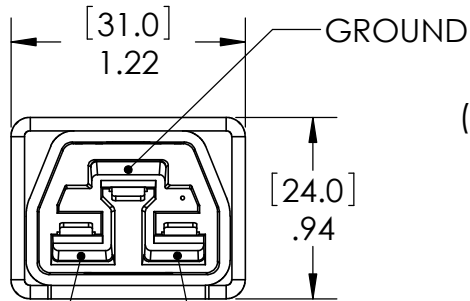

DIM "A"  
(3) PLC'S  
4

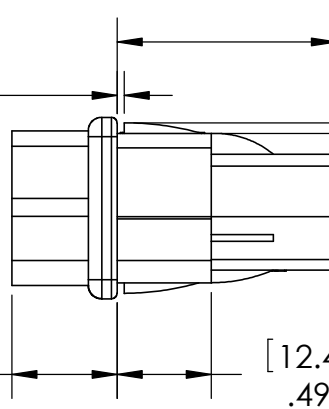

[1.40±0.38] 5  
.055±0.15 (2 PLCS)

NEGATIVE (-) POSITIVE (+)

**NOTES:**

PART ID LOCATED HERE

- FOR USE WITH IEC320 C14 PANEL CUT-OUTS.
- \*INDICATES NON STOCK ITEM. CONTACT FACTORY FOR AVAILABILITY.
- HOUSING MATERIAL: POLYCARBONATE
- SPRING MATERIAL: STAINLESS STEEL

CAT. NO. (SEE NOTE 2)	PANEL THICKNESS		DIM "A" <sup>+0.006[0.15]</sup> <sub>-.004[0.10]</sub>		PART ID
	INCH	MM	INCH	MM	
2005G1	.031	0.80	.036	0.91	"0.8"
2005G2*	.047	1.20	.056	1.42	"1.2"
2005G3	.039	1.00	.044	1.13	"1.0"
2005G4*	.063	1.60	.072	1.82	"1.6"
2005G5*	.079	2.00	.088	2.24	"2.0"
2005G6*	.098	2.50	.107	2.72	"2.5"

REV.	DESCRIPTION	APPRV	DATE
5	ECN 2016-0076 - ADDED 1.40mm DIMENSION	CPD	12/7/2016
4	ECRN 15520	CLY	11/25/2013
3	ECRN 15280	CLY	12/10/2012
2	ECRN 14928	NTS	6/24/11
1	ECRN 14681	NTS	7/30/2010

REVISIONS

DIMENSIONS ARE IN:	INCH [MM]	<b>APPROVALS</b>		<p><b>ANDERSON POWER PRODUCTS</b></p> <p><b>TITLE</b></p> <p>RECEPTACLE HOUSING FOR SAF-D-GRID® 2005 SERIES</p>
UNLESS OTHERWISE STATED		<b>DRAWN</b>	NTS 7/15/2010	
TOLERANCES:		<b>CHECKED</b>	DJD 7/15/2010	
DECIMALS (INCH) DECIMALS (MM) ANGLES		<b>MFG APPRV</b>	CHB 7/15/2010	
SURFACE FINISH:		<b>QC APPRV</b>	UFN 7/15/2010	
MACHINED 128µin [3.2µ]		<b>ENG APPRV</b>	BD 7/15/2010	
MOLDED 64µin [1.6µ]		<b>SIZE</b>	A	
MATERIAL: SEE NOTES		<b>DWG NO.</b>	114868S2	
FINISH: N/A		<b>REV.</b>	5	
3rd ANGLE PROJECTION		<b>SCALE</b>	NONE	
-CAD GENERATED DRAWING- DO NOT MANUALLY UPDATE DO NOT SCALE		<b>CADFILE</b>	03115	
		<b>SHEET</b>	1 OF 1	