

THE INFORMATION CONTAINED IN THIS DRAWING IS THE SOLE PROPERTY OF ANDERSON POWER PRODUCTS. ANY REPRODUCTION IN PART OR WHOLE WITHOUT THE WRITTEN PERMISSION OF ANDERSON POWER PRODUCTS IS PROHIBITED.

Copyright 2012

ANDERSON POWER PRODUCTS RESERVES THE RIGHT TO ALTER PRODUCT TYPES, THEIR TECHNICAL DATA, DIMENSION, STYLE AND ACCESSORIES WITHOUT PRIOR NOTIFICATION.

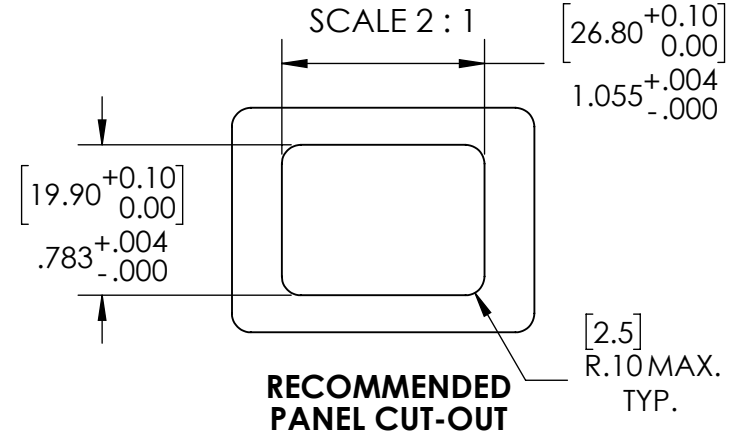
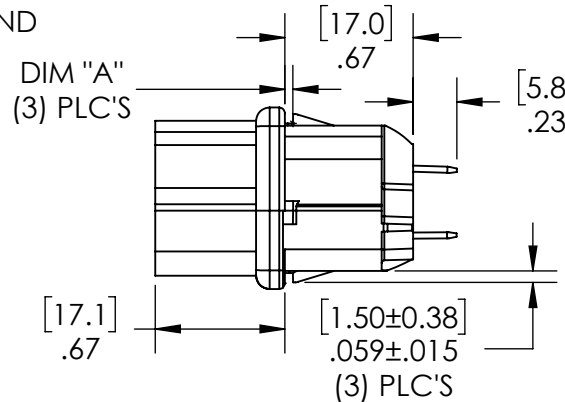
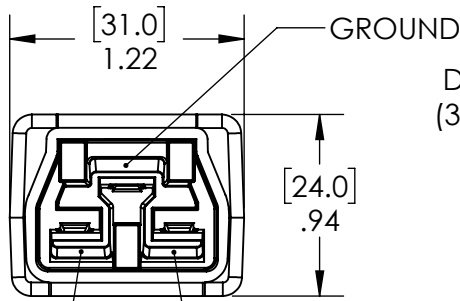
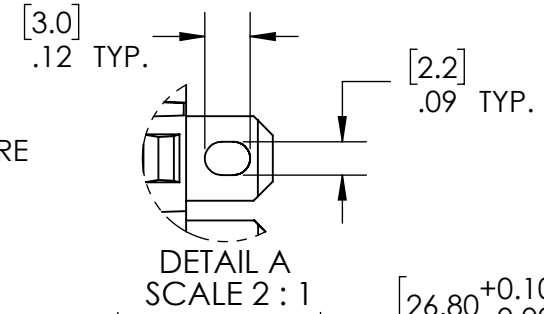
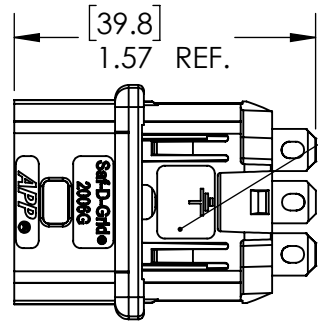
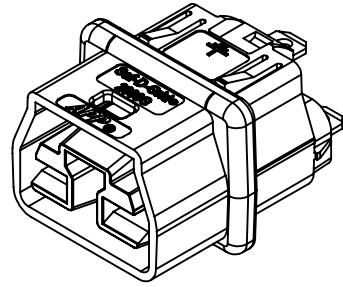

NOTES:

- HOUSING MATERIAL: HIGH TEMP. NYLON + 30% GF, UL 94 V-0, HALOGEN FREE
- SPRING MATERIAL: STAINLESS STEEL
- CONTACT MATERIAL: SILVER PLATED COPPER ALLOY
- OR USE WITH IEC320 C14 PANEL CUT-OUTS
- ELECTRICAL RATING:
20A, 600V NOT FOR CURRENT INTERRUPTION
20A, 400V FOR CURRENT INTERRUPTION
- TEMPERATURE RATING: 105°C

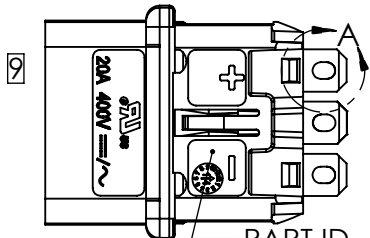

CAT. NO.	PANEL THICKNESS		DIM "A" ^{+0.006[0.15]} _{-.004[0.10]}		PART ID
	INCH	MM	INCH	MM	
2006G1	.031	0.80	.041	1.05	"0.8"
2006G2	.047	1.20	.056	1.42	"1.2"
2006G3	.039	1.00	.048	1.22	"1.0"
2006G4	.063	1.60	.072	1.82	"1.6"
2006G5	.079	2.00	.088	2.24	"2.0"
2006G6	.098	2.50	.107	2.72	"2.5"

REV.	DESCRIPTION	APPRV	DATE
10	ECN 2017-0049 ADDED TEMPERATURE RATING	AHR	5/18/2017
9	ECRN-15571	CLY	2/21/2014
8	ECRN-15520	CLY	11/25/2013
7	ECRN-15441	CLY	7/22/2013
6	ECRN 15377	CLY	4/4/2013
5	ECRN 15276	CLY	11/30/2012
4	ECRN 15265	CLY	11/2/2012

DIMENSIONS ARE IN:	INCH [MM]	APPROVALS		ANDERSON POWER PRODUCTS TITLE RECEPTACLE ASSEMBLY WITH CONTACTS, SAF-D-GRID® ULTRA SHORT, 2006 SERIES			
UNLESS OTHERWISE STATED		DRAWN	CLY 6/8/2012				
TOLERANCES:		CHECKED	NTS 6/8/2012				
DECIMALS (INCH) .XX ±.02	DECIMALS (MM) .X ±.5	ANGLES ±2°					
SURFACE FINISH:		MFG APPRV	CHB 6/8/2012				
MACHINED 128µin [3.2µ]		QC APPRV	HN 6/8/2012				
MOLDED 64µin [1.6µ]		ENG APPRV	BD 6/11/2012				
MATERIAL: SEE NOTES		SIZE	A	DWG NO.	115171S1	REV.	10
FINISH: N/A		SCALE	NONE	CADFILE	03741	SHEET	1 OF 1

REVISIONS

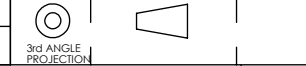

-CAD GENERATED DRAWING-
DO NOT MANUALLY UPDATE
DO NOT SCALE