

THE INFORMATION CONTAINED IN THIS DRAWING IS THE SOLE PROPERTY OF ANDERSON POWER PRODUCTS. ANY REPRODUCTION IN PART OR WHOLE WITHOUT THE WRITTEN PERMISSION OF ANDERSON POWER PRODUCTS IS PROHIBITED.

Copyright 2012

ANDERSON POWER PRODUCTS RESERVES THE RIGHT TO ALTER PRODUCT TYPES, THEIR TECHNICAL DATA, DIMENSION, STYLE AND ACCESSORIES WITHOUT PRIOR NOTIFICATION.

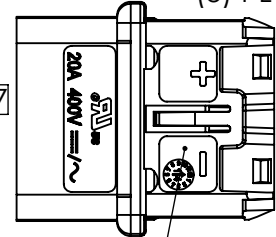
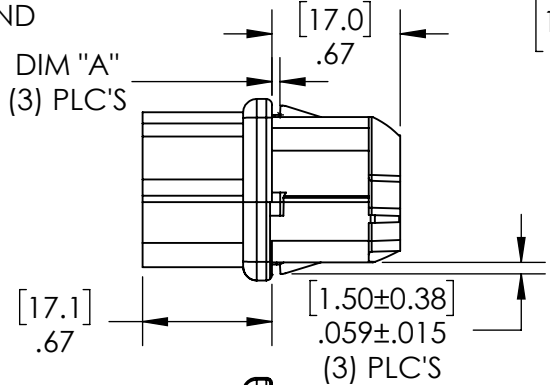
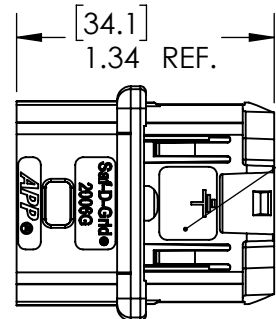
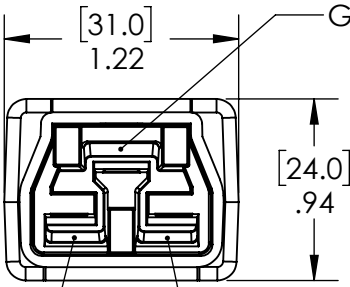
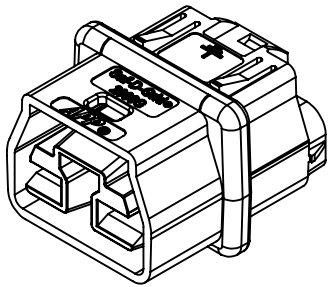

PART ID LOCATED HERE SEE TABLE

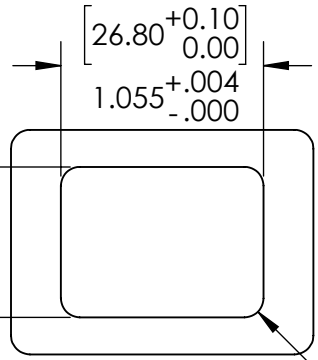

RECOMMENDED PANEL CUT-OUT

[2.5] R.10 MAX. TYP

NOTES:

1. HOUSING MATERIAL: HIGH TEMP. NYLON + 30%GF, UL 94 V-0, HALOGEN FREE
2. SPRING MATERIAL: STAINLESS STEEL
3. FOR USE WITH IEC320 C14 PANEL CUT-OUTS
4. ELECTRICAL RATING:
20A, 600V NOT FOR CURRENT INTERRUPTION
20A, 400V FOR CURRENT INTERRUPTION
5. TEMPERATURE RATING: 105°C

CAT. NO.	PANEL THICKNESS		DIM "A" ^{+0.006[0.15]} _{-.004[0.10]}		PART ID
	INCH	MM	INCH	MM	
2006G1-NC	.031	0.80	.041	1.05	"0.8"
2006G2-NC	.047	1.20	.056	1.42	"1.2"
2006G3-NC	.039	1.00	.048	1.22	"1.0"
2006G4-NC	.063	1.60	.072	1.82	"1.6"
2006G5-NC	.079	2.00	.088	2.24	"2.0"
2006G6-NC	.098	2.50	.107	2.72	"2.5"

REV.	DESCRIPTION	APPRV	DATE
8	ECN 2017-0049 ADDED ELEC. AND TEMP. RATING NOTES	CPD	5/19/2017
7	ECRN-15571	CLY	2/21/2014
6	ECRN-15520	CLY	11/25/2013
5	ECRN-15441	CLY	7/22/2013
4	ECRN 15377	CLY	4/4/2013
3	ECRN 15276	CLY	11/30/2012

DIMENSIONS ARE IN: INCH [MM]		APPROVALS		ANDERSON POWER PRODUCTS	
UNLESS OTHERWISE STATED TOLERANCES:		DRAWN	CLY	TITLE	
DECIMALS (INCH)	DECIMALS (MM)	CHECKED	NTS	RECEPTACLE HOUSING WITHOUT CONTACTS, SAF-D-GRID® ULTRA SHORT, 2006 SERIES	
.XX ± .02	.X ± .5	MFG APPRV	CHB	SIZE	DWG NO.
SURFACE FINISH:		QC APPRV	UFN	A	115171S2
MACHINED	128µin [3.2µ]	ENG APPRV	BD	SCALE	CADFILE
MOLDED	64µin [1.6µ]			NONE	03742
MATERIAL: SEE NOTES				SHEET	1 OF 1
FINISH: N/A		-CAD GENERATED DRAWING- DO NOT MANUALLY UPDATE DO NOT SCALE			

D
C
B
A

D
C
B
A