

THE INFORMATION CONTAINED IN THIS DRAWING IS THE SOLE PROPERTY OF ANDERSON POWER PRODUCTS. ANY REPRODUCTION IN PART OR WHOLE WITHOUT THE WRITTEN PERMISSION OF ANDERSON POWER PRODUCTS IS PROHIBITED.

Copyright 2014

ANDERSON POWER PRODUCTS RESERVES THE RIGHT TO ALTER PRODUCT TYPES, THEIR TECHNICAL DATA, DIMENSION, STYLE AND ACCESSORIES WITHOUT PRIOR NOTIFICATION.

ITEM NO.	2002G1KIT/QTY.	2002G2KIT/QTY.	2002G3KIT/QTY.	2002G4KIT/QTY.	PART NUMBER	DESCRIPTION	MATERIAL	FINISH
1	1	-	-	-	2002G1-BK	SAF-D-GRID STD. RECEPT, 0.8MM PANEL	POLYCARBONATE / ST. STEEL SPRINGS	BLACK
	-	1	-	-	2002G2-BK	SAF-D-GRID STD. RECEPT, 1.2MM PANEL	POLYCARBONATE / ST. STEEL SPRINGS	BLACK
	-	-	1	-	2002G3-BK	SAF-D-GRID STD. RECEPT, 1.0MM PANEL	POLYCARBONATE / ST. STEEL SPRINGS	BLACK
	-	-	-	1	2002G4-BK	SAF-D-GRID STD. RECEPT, 1.6MM PANEL	POLYCARBONATE / ST. STEEL SPRINGS	BLACK
2	1	1	1	1	-	16AWG RED WIRE WITH 2003G1 CONTACT	SEE NOTES	SEE NOTES
3	1	1	1	1	-	16AWG BLACK WIRE WITH 2003G1 CONTACT	SEE NOTES	SEE NOTES
4	1	1	1	1	-	16AWG GREEN/YELLOW WIRE WITH 2003G1 CONTACT	SEE NOTES	SEE NOTES

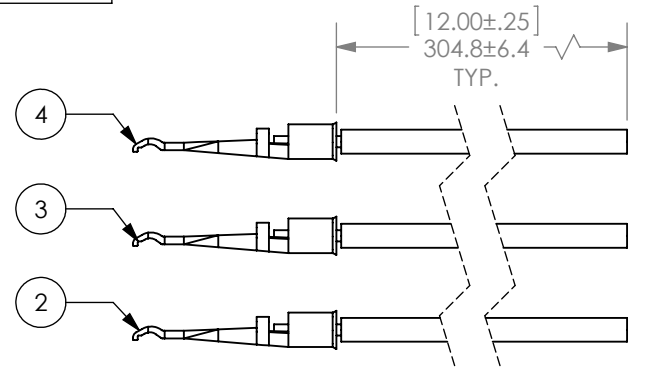
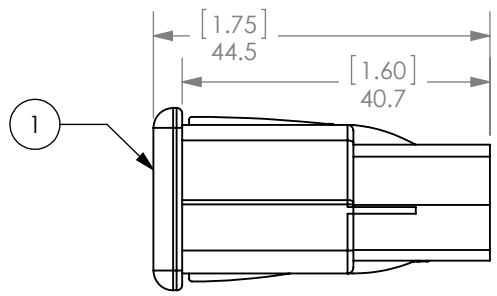
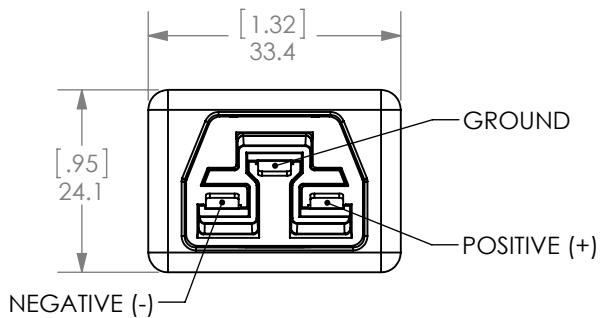
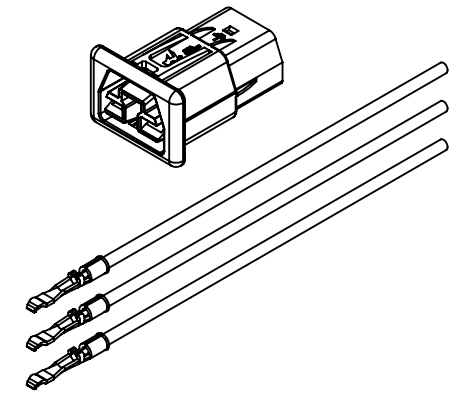

- NOTES:
- FOR USE WITH IEC C14 PANEL CUT-OUTS.
 - CONTACT/WIRE ASSEMBLY MATERIAL/FINISH:
CONTACT: SILVER PLATED COPPER ALLOY
WIRE: TINNED COPPER WITH PVC JACKET, COLOR PER DESCRIPTION IN TABLE.
 - WIRE IS UL LISTED 600V, 105°C

DIMENSIONS ARE IN:	MM [INCH]	APPROVALS	
UNLESS OTHERWISE STATED		DRAWN	
TOLERANCES:		CLY	3/4/2014
DECIMALS (INCH)	DECIMALS (MM)	CHECKED	
.XX ± .02	.X ± .5	MC	3/4/2014
SURFACE FINISH:		MFG APPRV	
MACHINED	3.2µ [128µin]	CHB	3/5/2014
MOLDED	1.6µ [64µin]	QC APPRV	
MATERIAL:		HN	3/5/2014
SEE TABLE		ENG APPRV	
FINISH:		BD	3/5/2014
SEE TABLE			

ANDERSON POWER PRODUCTS		
TITLE		
SAF-D-GRID® 2002 SERIES RECEPTACLE KIT WITH #16AWG WIRES		
SIZE	DWG NO.	REV.
A	115353S1	0

REV.	DESCRIPTION	APPRV	DATE
REVISIONS			

3rd ANGLE PROJECTION

-CAD GENERATED DRAWING-
DO NOT MANUALLY UPDATE
DO NOT SCALE

SCALE	CADFILE	SHEET
NONE	04207	1 OF 1