

THE INFORMATION CONTAINED IN THIS DRAWING IS THE SOLE PROPERTY OF ANDERSON POWER PRODUCTS. ANY REPRODUCTION IN PART OR WHOLE WITHOUT THE WRITTEN PERMISSION OF ANDERSON POWER PRODUCTS IS PROHIBITED.

Copyright 2023

ANDERSON POWER PRODUCTS RESERVES THE RIGHT TO ALTER PRODUCT TYPES, THEIR TECHNICAL DATA, DIMENSION, STYLE AND ACCESSORIES WITHOUT PRIOR NOTIFICATION.

D
C
B
A

D
C
B
A

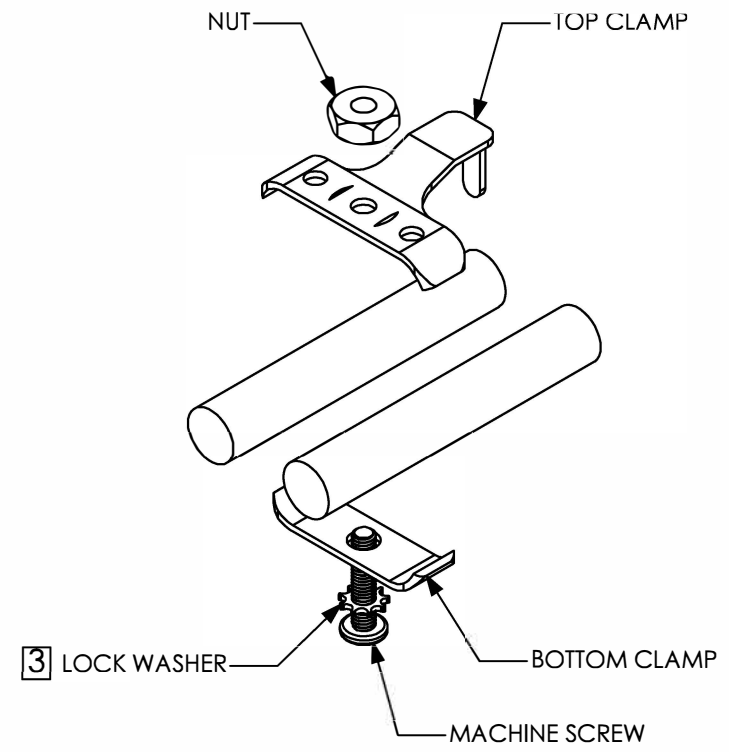
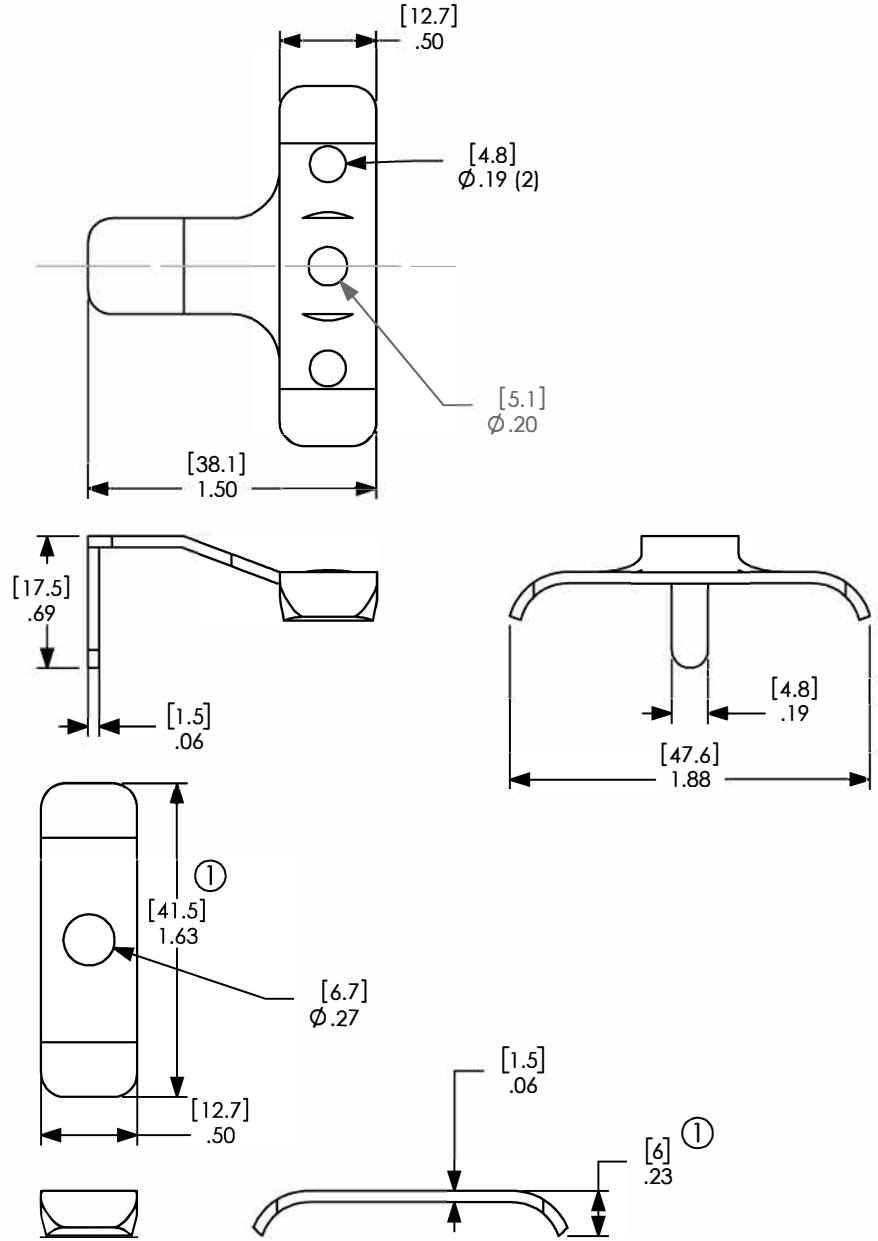

DIMENSIONS ARE IN:		INCH [MM]		APPROVALS		ANDERSONPOWER™	
UNLESS OTHERWISE STATED							
TOLERANCES:				DRAWN		TITLE CAT. NO. 945: SB175 CABLE CLAMP FOR SINGLE CONDUCTOR #4AWG TO 1/0	
DECIMALS (INCH)		DECIMALS (MM)		CHECKED			
.XX ± .02		.X ± .5		MFG APPRV			
				QC APPRV			
SURFACE FINISH:				RPO		COA	
MACHINED		128µin [3.2µ]		2/7/2000		PROD. LINE	
MOLDED		64µin [1.6µ]		2/8/2000			
MATERIAL:				ENG APPRV		SIZE	
SEE NOTES				UFN		DWG NO.	
FINISH:				2/8/2000		114228S1	
SEE NOTES				-CAD GENERATED DRAWING- DO NOT MANUALLY UPDATE DO NOT SCALE		SCALE	
				1:1		SHEET	
				01186		1 OF 1	

3	ECN 2024-0002 - UPDATED LOCK WASHER GEOMETRY	CPD	1/3/2024
2	ECRN 14849 - CLAMP THICKNESS DIM	TWE	3/8/11
1	ECRN 14168 - 1.63 WAS 1.51, .23 WAS .14	CMS	6/11/07
REV.	DESCRIPTION OF CHANGES	APPROVED	DATE

