

THE INFORMATION CONTAINED IN THIS DRAWING IS THE SOLE PROPERTY OF ANDERSON POWER PRODUCTS. ANY REPRODUCTION IN PART OR WHOLE WITHOUT THE WRITTEN PERMISSION OF ANDERSON POWER PRODUCTS IS PROHIBITED.

Copyright 2011

ANDERSON POWER PRODUCTS RESERVES THE RIGHT TO ALTER PRODUCT TYPES, THEIR TECHNICAL DATA, DIMENSION, STYLE AND ACCESSORIES WITHOUT PRIOR NOTIFICATION.

D

C

B

A

D

C

B

A

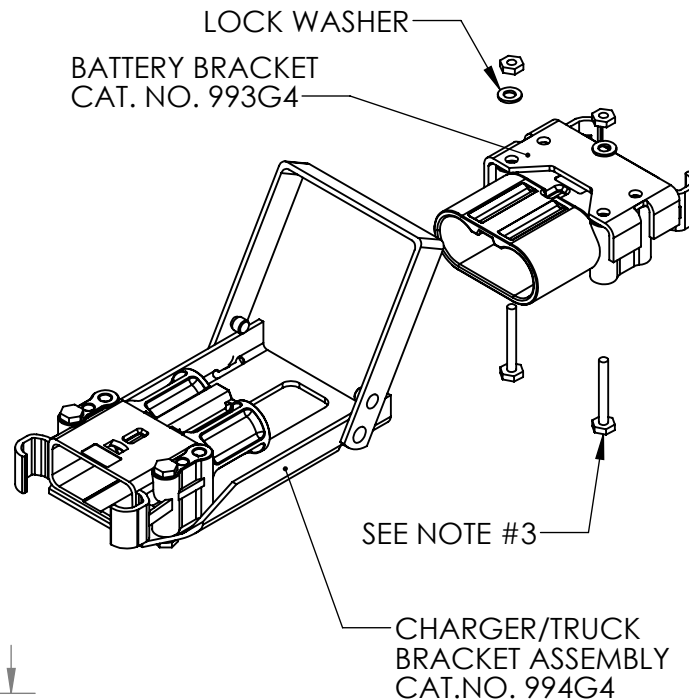
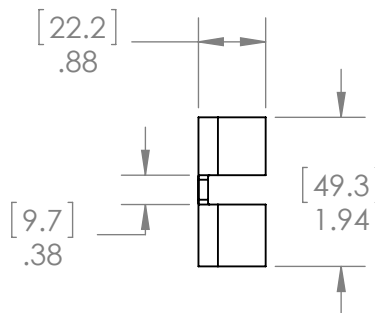
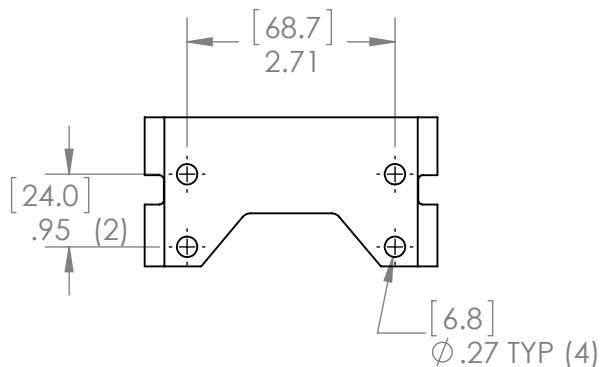
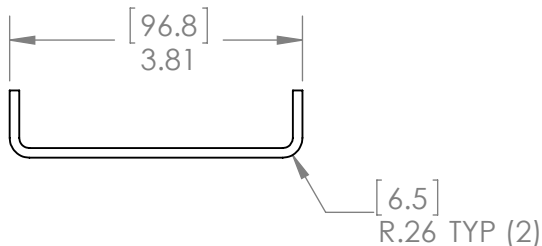

NOTES:

1. MATERIAL = .125 THK COLD ROLLED STEEL
2. FINISH = ELECTROSTATIC POWDER COAT EPOXY - CRIMSON
3. MOUNTING HARDWARE INCLUDED WITH CAT. NO.993G4 (BATTERY BRACKET)
4. USE WITH CAT .NO. 994G4 (CHARGER/TRUCK BRACKET ASSEMBLY)
5. CONNECTORS SOLD SEPARATELY

DIMENSIONS ARE IN:	INCH [MM]	APPROVALS			ANDERSON POWER PRODUCTS			
UNLESS OTHERWISE STATED		DRAWN	TWE		7/20/11	TITLE BATTERY BRACKET EBC-320 MANUAL RELEASE CATALOG NUMBER 993G4		
TOLERANCES:		CHECKED	CMS	7/21/11				
DECIMALS (INCH)	DECIMALS (MM)	ANGLES	MFG APPRV	BD	7/21/11			
.XX ±.02	.X ±.5	±2°	QC APPRV	UFN	7/21/11			
SURFACE FINISH:		MATERIAL:		ENG APPRV		SIZE	DWG NO.	REV.
MACHINED 128µin [3.2µ]		SEE NOTES		BD		A	114530S2	0
MOLDED 64µin [1.6µ]		FINISH:		SEE NOTES		SCALE	CADFILE	SHEET
						NONE	03531	1 OF 1
				-CAD GENERATED DRAWING- DO NOT MANUALLY UPDATE DO NOT SCALE				

REV.	DESCRIPTION	APPRV	DATE
REVISIONS			