

THE INFORMATION CONTAINED IN THIS DRAWING IS THE SOLE PROPERTY OF ANDERSON POWER PRODUCTS. ANY REPRODUCTION IN PART OR WHOLE WITHOUT THE WRITTEN PERMISSION OF ANDERSON POWER PRODUCTS IS PROHIBITED.

Copyright 2017

ANDERSON POWER PRODUCTS RESERVES THE RIGHT TO ALTER PRODUCT TYPES, THEIR TECHNICAL DATA, DIMENSION, STYLE AND ACCESSORIES WITHOUT PRIOR NOTIFICATION.

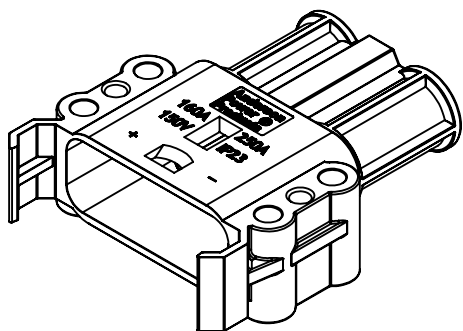

4

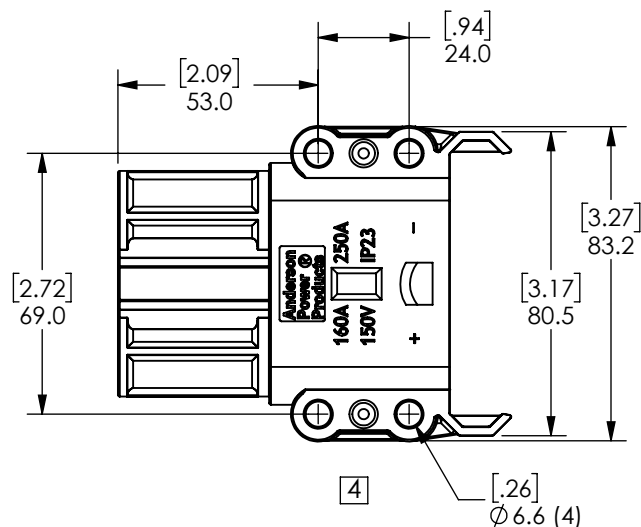

4

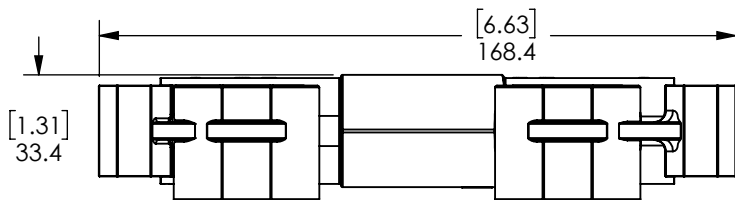

MATED PAIR

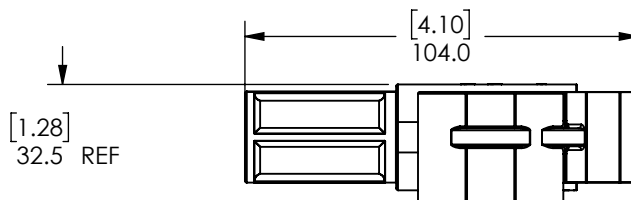

PART NO.	DESCRIPTION	MATERIAL	COLOR
160-2	ABC SOCKET HSG. (160A)	NYLON	BLACK
EP160-2	EBC SOCKET HSG. (160A)	PBT-PC BLEND	BLACK

4

DIMENSIONS ARE IN:	MM [INCH]	APPROVALS		ANDERSON POWER PRODUCTS TITLE 160A FEMALE SOCKET HOUSING FOR DIN CONNECTORS			
UNLESS OTHERWISE STATED		DRAWN	AMP 6/7/2005				
TOLERANCES:		CHECKED	DJD 6/9/2005				
DECIMALS (INCH) DECIMALS (MM) ANGLES .XX ± .015 .X ± .38 ±.5° .XXX ± .005 .XX ± .13		MFG APPRV	CHB 6/7/2005				
SURFACE FINISH:		QC APPRV	JJA 6/9/2005				
MACHINED 3.2µ [128µin] ✓ MOLDED 1.6µ [64µin] ✓		ENG APPRV	DAM 6/8/2005				
MATERIAL:		SIZE	A	DWG NO.	E160-2S1	REV.	4
SEE TABLE		SCALE	1:2	CADFILE	02357	SHEET	1 OF 1
FINISH:		-CAD GENERATED DRAWING- DO NOT MANUALLY UPDATE DO NOT SCALE					
N/A							

A

REV.	DESCRIPTION	APPRV	DATE
4	ECN 2023-0042 - VDE, EN1175 CURRENT RATING	CPD	5/30/2023
3	ECN 2017-0025	CMS	4/11/2017
2	ECRN 14292:- REMOVE "E" & "EN" SERIES PART NUMBERS	AMS	7/25/08
1	ECRN 13946: ADD "EP" & "EN" SERIES PART NUMBERS	AMS	1/19/06
REVISIONS			