

## SBX®350 / SBE®320 DOUBLE STACK ASSEMBLY



Double Stack Bracket and Handle Assembly



Battery Bracket



Charger / Truck Middle Plate



SBX®350 / SBE®320 Spacer (2X)

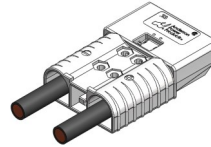

SBX® Connector Assembly (4X)



Hex Bolt  
 $\frac{1}{4}$  - 20 x 3 (4X)  
 $\frac{1}{4}$  - 20 x 2 -  $\frac{3}{4}$  (4X)



NUT, HEX,  
 $\frac{1}{4}$ -20 (8X)



WASHER,  
 $\frac{1}{4}$  (8X)

**Tools You Will Need** • Wrench Open End \* Lubricant (Optional)

**IMPORTANT:** Refer to 1S6832A for guidelines on paralleling conductors

### PREPARING THE CHARGER / TRUCK CONNECTOR ASSEMBLY

1. Align 2 Connector Housings, Spacer, Middle Plate and Double Stack Bracket and Handle Assembly as shown (see figure 1).
2. Pass 3 inch Hex Bolts through all components.
3. Align Protruding Bolts of the Charger / Truck with holes on Fixed Panel. See appendix for hole pattern, page 2.
4. Secure components using (4) Hex Bolts, (4) Washers and (4) Nuts.
5. Tighten the Nuts with a torque value of 65 (in-lbs) / 7.3 (Nm).

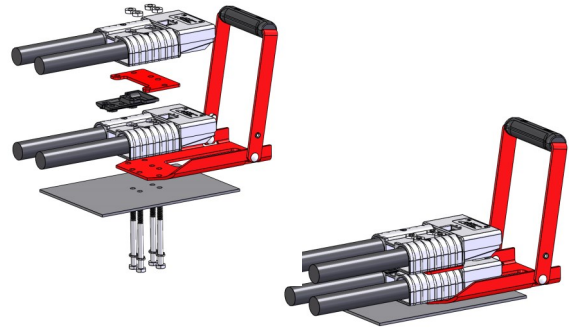

Figure 1

### PREPARING THE BATTERY CONNECTOR ASSEMBLY

6. Align 2 Connector Housings, Spacers, Battery Bracket and insert 2 $\frac{3}{4}$  inch Hex Bolts shown (see figure 2).
  7. Lightly secure the Nuts to the Hex Bolts.
  8. Insert Battery Connector Assembly into the Truck / Charger Assembly as shown (see figure 3).
- Align the slots in the Battery Bracket to the Pins in the Truck / Charger Assembly as shown (see figure 4).
  - Drop Battery Connector Assembly onto the Pins as shown (see figure 5).

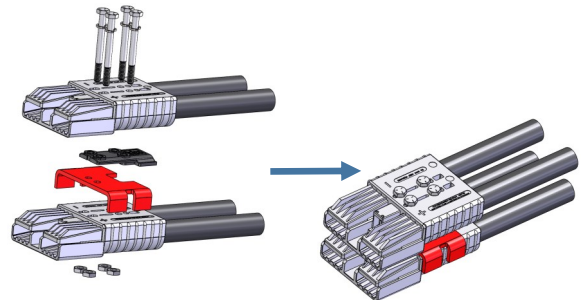

Figure 2

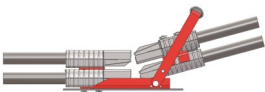

Figure 3

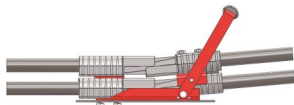

Figure 4

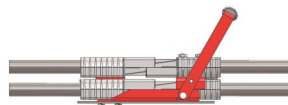
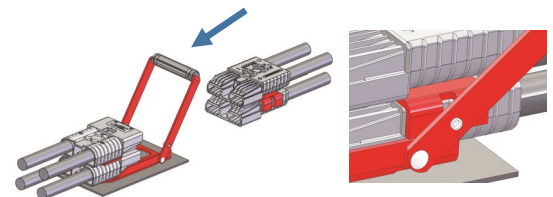

Figure 5



9. Push the Handle so that the Connector Assemblies are mated as shown (see figure 6). If there is a slight gap between connectors, force the battery connector assembly forward until the gap is closed before tightening the bolts
10. Tighten the front (1) Nuts on the Battery Connector Assembly to a torque value of 65 (in-lbs) / 7.3 (Nm) as shown (see figure 7).
11. Tighten the back (2) Bolts on the Battery Connector Assembly to a torque value of 65 (in-lbs) / 7.3 (Nm) as shown (see figure 7).
12. Close the Lever to mate the Battery Connector Assembly to the Charger / Truck Connector Assembly.
13. SBX®350 / SBE®320 DOUBLE STACK ASSEMBLY is complete as shown (see figure 8).

- (OPTIONAL) - To reduce friction between the housings and reduce mating force, white lithium grease can be applied to the mating faces of the contacts and housings, see Preventative Maintenance under Resources at [www.andersonpower.com](http://www.andersonpower.com)

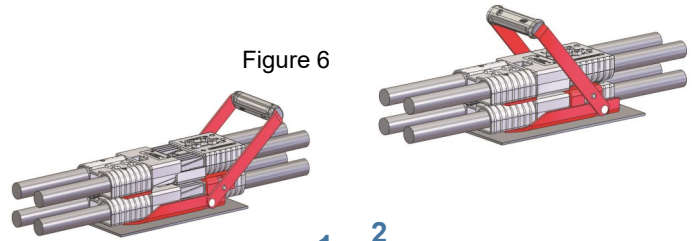

Figure 6

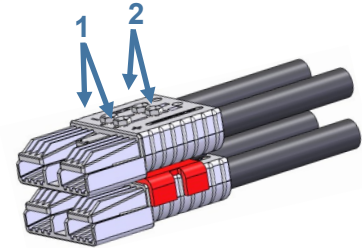

Figure 7

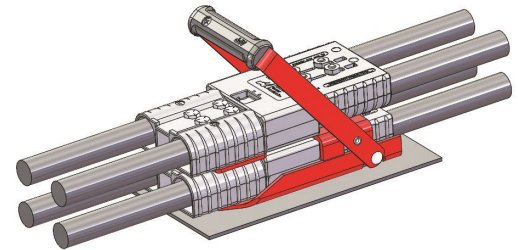
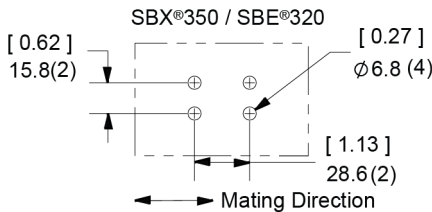

Figure 8  
Fully Assembled

## Hole Pattern Appendix



All Data Subject to Change Without Notice

2023-0043 1S6827 Rev 2

Your Best Connection™

Anderson™ will use reasonable efforts to include accurate and up-to-date content in the assembly instruction. All product information contained in the instruction sheet including ordering information, illustrations, specifications, and dimensions, are believed to be reliable as of the date of publishing, but is subject to change without notice. Anderson™ makes no warranty or representation as to its accuracy. Content in the instruction sheet may contain technical inaccuracies, typographical errors and may be changed or updated without notice. Anderson™ may also make improvements and/or changes to the products and/or to the programs described in the content at any time without notice. Current sales drawings and specifications are available upon request.

© 2023 Anderson Power Products, Inc. All rights reserved. Anderson Power Products®, SBE®, SBX® and the logo are registered trademarks of Anderson Power Products, Inc. Anderson™ and Your Best Connection™ are Trademarks of Anderson Power Products, Inc.



**HEADQUARTERS:** Anderson Power Products®, 13 Pratts Junction Road, Sterling, MA 01564-2305 USA T: +1 978-422-3600 F: +1 978-422-0128 • **EUROPE:** Anderson Power Products® Ltd., Unit 3, Europa Court, Europa Boulevard, Westbrook, Warrington, Cheshire, WA5 7TN United Kingdom T: +44 (0) 1925 428390 F: +44 (0) 1925 520203 • **ASIA / PACIFIC:** IDEAL® Anderson Asia Pacific Ltd., Unit 922-928 Topsail Plaza, 11 On Sum Street, Shatin N.T., Hong Kong T: +(852) 2636 0836 F: +(852) 2635 9036 • **CHINA:** IDEAL® Anderson Technologies (Shenzhen) Ltd., Block A8 Tantou Western Industrial Park, Songgang Baoan District, Shenzhen, PR. China 518105 T: +(86) 755 2768 2118 F: +(86) 755 2768 2218 • **GERMANY:** IDEAL® Industries Germany GmbH, Esslinger Strasse 7, D – 70771 Leinfelden-Echterdingen, T: +49 (0) 711 – 997606666 • **INDIA:** IDEAL® INDUSTRIES India Private Limited, 229-230, SPAZEDGE, Tower B, Sector 47, Sohna Road, Gurgaon – 122018, Haryana, India T: +(91) 956 007 5905 [www.ideal-industries.in](http://www.ideal-industries.in) • [www.andersonpower.com](http://www.andersonpower.com)